

# An overview of using directional antennas in wireless networks

Hong-Ning Dai<sup>1,3,\*</sup>, Kam-Wing Ng<sup>2</sup>, Minglu Li<sup>3</sup> and Min-You Wu<sup>3</sup>

<sup>1</sup>*Faculty of Information Technology, Macau University of Science and Technology, Avenida Wai Long, Taipa, Macau, China*

<sup>2</sup>*Department of Computer Science and Engineering, The Chinese University of Hong Kong, Shatin, NT, Hong Kong, China*

<sup>3</sup>*Department of Computer Science and Engineering, Shanghai Jiao Tong University, Shanghai, China*

## SUMMARY

Compared with omni-directional antennas, directional antennas have many merits, such as lower interference, better spatial reuse, longer transmission range, and improved network capacity. Directional antennas enable numerous emerging outdoor and indoor applications, which have been addressed in many recent studies. Despite the advances in wireless networks with directional antennas (DAWNs), there are many research challenges in all layers of DAWNs. This paper presents a detailed study on recent advances and open research issues on DAWNs. Firstly, we briefly introduce the classification of directional antennas, antenna radiation patterns, antenna modes, and the challenges in the physical layer of DAWNs. We then present research issues on the medium access control (MAC) layer, followed by the current solutions as well as open research problems on the MAC layer of DAWNs. In addition, we also discuss the research issues on the routing layer and the transport layer. Moreover, other research challenges on the performance evaluation of DAWNs and a brief introduction of indoor DAWNs are given in this paper as well. In conclusion, we summarize the current research issues on DAWNs as well as prospects in the future. Copyright © 2011 John Wiley & Sons, Ltd.

Received 9 February 2011; Revised 16 June 2011; Accepted 9 August 2011

KEY WORDS: wireless networks; directional antennas; medium access control; routing

## 1. INTRODUCTION

Nowadays, wireless networks have numerous emerging applications, ranging from backbone wireless mesh networks, to last-mile wireless networks, and to Wi-Fi direct networks. We can categorize the various application scenarios into two types: (i) indoor wireless networks and (ii) outdoor wireless networks. Indoor wireless networks include last-mile wireless networks and Wi-Fi direct networks, which usually have shorter links than outdoor wireless networks. Compared with indoor wireless networks, outdoor wireless networks often serve as the network backbone or infrastructure for Internet connection and usually have longer transmission range. Besides, a data transmission in indoor wireless networks usually traverses through one hop whereas it may take multiple hops in outdoor wireless networks.

Both indoor and outdoor wireless networks typically consist of the nodes equipped with omni-directional antennas. As omni-directional antennas spread radio signals in all directions, all neighboring nodes around a pair of communication nodes (i.e., the transmitter and the receiver) are prevented from transmitting to avoid collisions. Therefore, the capacity of wireless networks using omni-directional antenna is limited because of the high interference and the low spatial reuse. We call such wireless networks using omni-directional antennas as *WONs*.

\*Correspondence to: Hong-Ning Dai, Faculty of Information Technology, Macau University of Science and Technology, Avenida Wai Long, Taipa, Macau, China.

†E-mail: hndai@ieee.org

Many other studies consider using directional antennas instead of omni-directional antennas in both indoor and outdoor wireless networks. Compared with an omni-directional antenna, a directional antenna can concentrate its transmitting or receiving capabilities to a certain direction. Thus, using directional antennas in wireless networks allows more concurrent transmissions in the vicinity of a pair of communication nodes and consequently leads to less interference to other on-going transmissions. We call such wireless networks using directional antennas as *DAWNs*, which usually have much higher network capacity than *WONs*.

*DAWNs* have much more benefits than *WONs* despite many design challenges that restrict the wide application of directional antennas in wireless networks. Besides, using directional antennas in indoor environments usually leads to more challenges than that in outdoor environments. Thus, the solutions to indoor *DAWNs* are quite different from those to outdoor *DAWNs* (we will discuss research issues on indoor *DAWNs* in Section 5.3). In this paper, we mainly concentrate on outdoor *DAWNs*, but some discussions may apply to indoor *DAWNs* as well.

### 1.1. Pros and cons of directional antennas

Compared with *WONs*, *DAWNs* have the following advantages.

- *Lower interference*: At transmitter side, a directional antenna concentrates transmitting signals to one direction, which leads to no interference or less interference with other transmissions. On the other hand, at receiver side, a directional antenna can shield interference from other transmitters.
- *Improved spatial reuse*: Compared with omni-directional antennas, directional antennas also allow more concurrent transmissions in the vicinity of the transmitter or the receiver.
- *Longer transmission range*: By focusing radio signals to a certain direction, a directional antenna acquires a higher antenna gain than an omni-directional antenna, which consequently leads to a longer transmission range (given the same transmission power).
- *Reduced power requirement*: To maintain a successful link, the minimum transmission power is inversely proportional to the product of the antenna gains of both the transmitter and the receiver. As directional antennas have higher antenna gains than omni-directional antennas, the use of directional antennas results in the reduced power requirement.

With the benefits brought by directional antennas, *DAWNs* potentially have the higher capacity and the better routing performance than *WONs*. In particular, the analysis in [1] shows that a *DAWN* achieves a network capacity gain of  $2\pi/\sqrt{\alpha\beta}$  over a *WON* when both transmission and reception are directional, where  $\alpha$  and  $\beta$  denote the transmitter antenna beamwidth and the receiver antenna beamwidth, respectively. Other theoretical studies [2–5] have further confirmed this result. Besides, experimental studies [6–11] have also shown that using directional antennas in wireless networks can significantly improve the network throughput. Moreover, the increased transmission range brought by directional antennas leads to fewer hops, which results in the improved routing performance (i.e., shorter delay) of *DAWNs* than *WONs* [8, 12–14].

Despite their numerous advantages, directional antennas also have the following drawbacks and limitations, which restrict their application from wireless networks.

- *Device complexity*: It often requires complicated algorithms to direct the antenna *beams*, combine the multipath signals, and adjust *nulling* to interfering nodes. Therefore, the transceivers equipped with directional antennas must include more powerful processors and control units. It is a challenge to equip directional antennas with the portable devices that often only have a low-processing capability.
- *Physical size*: A directional antenna is usually implemented through a number of antenna elements. In general, the antenna *gain*, which determines the antenna capability, is proportional to the number of antenna elements. This means that a number of antenna elements are necessary to obtain a reasonable antenna gain (e.g., to reach a given transmission range). However, a large number of antenna elements inevitably lead to the bulky size of antennas, which limits the application of directional antennas in wireless networks, especially for indoor wireless networks.

- *Unique physical characteristics:* Directional antennas have unique characteristics in physical layer (e.g., the directionality), which have impacts on the upper layers. In particular, there are many research challenges in medium access control (MAC) layer, the routing layer, and the transport layer.

### 1.2. Our contributions

There are a number of studies on DAWNs. Most of them are only focused on design and implementation issues of DAWNs. However, there are few studies offering comprehensive overviews on advances and research challenges on different layers in DAWNs. Therefore, we present a survey on DAWNs in this paper. In particular, we (i) summarize the research challenges on different layers of DAWNs; (ii) compare the current solutions and offer implications on DAWNs; and (iii) present prospects for the future studies on DAWNs.

More specifically, we categorize the research issues on DAWNs into the following types according to the different network layers.

1. *Physical layer:* The impacts of directional antennas on the physical layer include the different types of directional antennas, the antenna radiation pattern, the directionality of directional antennas, the antenna size, and computation complexity.
2. *MAC layer:* The unique properties of directional antennas introduce difficulties in designing MAC protocols. In particular, directional beamforming leads to the new location-dependent carrier-sensing problems, for example, the hidden terminal problem and the deafness problem, which significantly affect the network performance. Besides, localization and neighbor discovery also lead to challenges on the MAC design on DAWNs.
3. *Routing layer:* The impacts of directional antennas on both the physical layer and the MAC layer affect the protocol design in other layers, especially for the routing layer. More specifically, directional localization and neighbor discovery bring difficulties in building and maintaining the routing paths. In addition, the routing performance significantly degrades because of the hidden terminal problem and the deafness problem in DAWNs.
4. *Other research issues:* We address the research problems in the transport layer because of the impacts of directional routing and the head-of-line blocking (HOLB) problem in DAWNs. Besides, we also present the challenges on the performance evaluation of DAWNs as well as the difficulties in indoor directional systems.

Although there are some related surveys on DAWNs [15–19], they are only concentrated on a particular layer of DAWNs. For example, the studies [16–19] are only focused on the MAC layer but the survey [15] just offers an overview on smart antennas on the physical layer.

The remaining paper is organized as follows. In Section 2, we provide a brief overview of various directional antennas, their classification, and the challenges of directional antennas in the physical layer. The MAC issues related to DAWNs are presented in Section 3. In Section 4, we discuss the research challenges in the routing layer of DAWNs. Section 5 addresses other research issues on DAWNs. Finally, we conclude the paper in Section 6.

## 2. DIRECTIONAL ANTENNAS

To clarify the concepts of directional antennas, we give a brief introduction of directional antennas as well as a classification of directional antennas in Section 2.1. Sections 2.2 and 2.3 present current radiation patterns of directional antennas and antenna modes, respectively. We discuss the challenges on directional antennas in Section 2.4.

### 2.1. Antennas and their classification

The classification of various antennas is shown in Figure 1. In general, an antenna is a device that is used for radiating/collecting electromagnetic energy (radio signals) into/from space. Among various antenna types, *omni-directional* antennas are commonly used in wireless networks. One hypothetical omni-directional antenna, called *isotropic*, is a point in space that radiates power in all directions

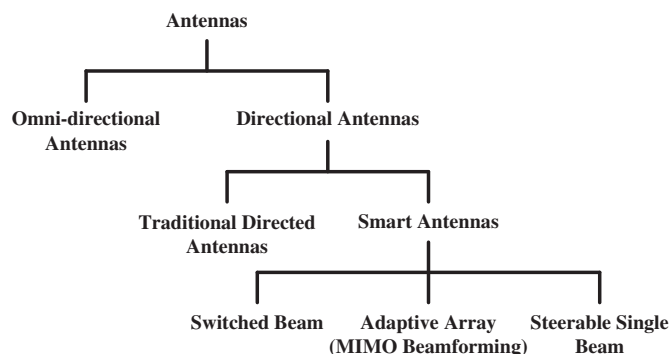

Figure 1. Antenna classification.

equally. This ideal antenna is often taken as a reference model of practical antennas. A half-wave *dipole* is a practical omni-directional antenna, which has a circular radiation pattern in the *azimuth* plane or in the *elevation* plane. As an omni-directional antenna radiates radio signals in all directions, only a small percentage of them can reach the desired nodes and most of them are scattered into space. The scattered radio signals can cause interference with nodes within the coverage of the antenna. Besides, omni-directional antennas have low efficiency in the frequency reuse as a number of channels are required to avoid interference.

A directional antenna is an antenna (directed antenna) or an antenna system (an array of antennas), which can radiate or receive radio signals more effectively in some directions than in others. There are two kinds of directional antennas:

- *Traditional directed antennas* include Helix, Yagi-Uda, aperture horn (e.g., pyramidal, conical horns), reflector (e.g., parabolic grid antenna), and patch antennas. The beam formed by the antennas is either fixed or adjusted to point to a certain direction by mechanical rotation.
- A *smart antenna* is an antenna array consisting of a set of antenna elements (in a linear, planar, or circular array) with digital signal processing capability to transmit and receive adaptively. Compared with traditional directed antennas, smart antennas usually possess superior capabilities, such as directional beamforming, diversity processing, and adaptive spatial reusing.

A smart antenna consists of not only a number of radiating elements but also a combining/dividing network and a control unit. The control unit that is normally implemented by using a digital signal processor (DSP) is the brain of a smart antenna. Many terms have been used to refer to smart antennas, which include intelligent antennas, phased array, spatial processing, digital beamforming, and adaptive antenna systems. In this paper, we denote all these antennas as smart antennas.

Smart antennas can be categorized as the following types:

- *Switched beam*: The antenna beam patterns are predetermined by shifting every antenna element's signal phase. Weights for antenna elements, which are used to produce the desired beam pattern, can be locally saved in memory and instantaneously switched. Figure 2(a) is an example of switched-beam antennas.
- *Steerable single beam antenna* (dynamically phased array): In this system as shown in Figure 2(b), arbitrary beam patterns are formed on the fly. Besides, the radiation pattern can be adjusted toward the users whereas directions toward interference sources are set to be null (or zero), which is called *nulling* capability. These techniques can maximize the signal to interference and noise ratio (SINR) [15].
- *Adaptive array*: In addition to the nulling capability and the dynamical forming of beam patterns, the radiation pattern can be adapted to receive multipath signals by using space diversity algorithms and techniques, as shown in Figure 2(c). Moreover, the use of multiple adaptive array antennas at both the transmitter and the receiver (is also called MIMO beamforming [20–22]) can further improve the performance in multipath environments.

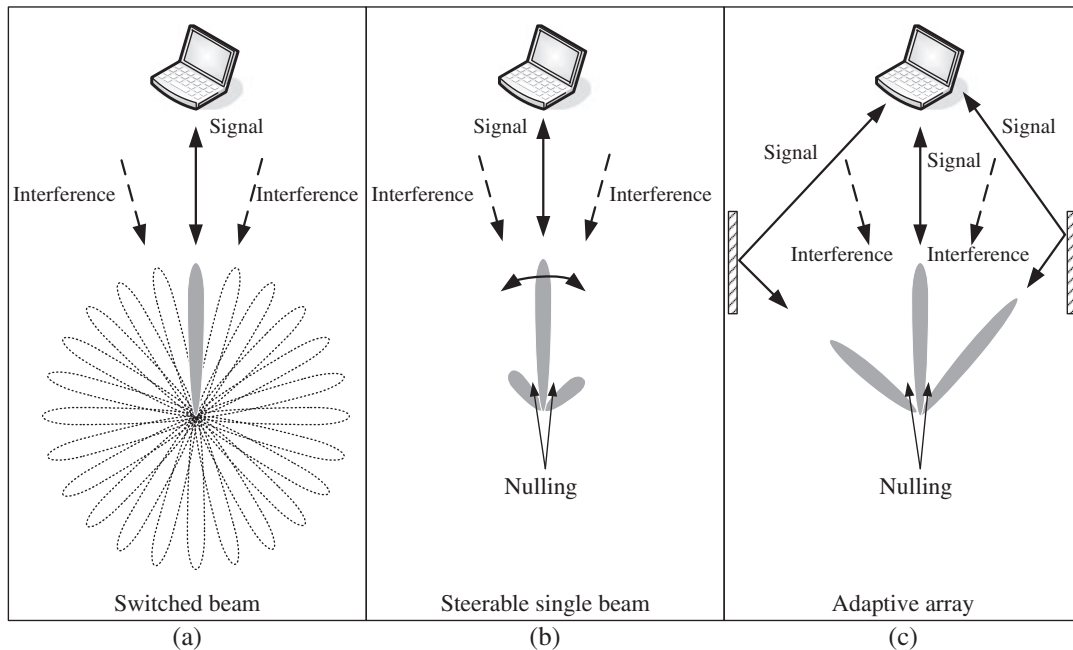

Figure 2. Smart antennas.

*Sectored* antennas are also assumed to be used in many studies including [6, 7, 23–30]. Sectored antenna systems are typically used in cellular networks, where a sectored antenna subdivides the area covered by an omni-directional antenna into sectors. Each sector is regarded as a different cell, which offers a longer range than that of omni-directional antennas. Sectored antennas can select one or multiple sectors to receive or transmit at a time. In general, sectored antennas can be treated as switched beam antennas if only one sector is active at a time. This is true if the sectored antenna has a single interface. In this case, its omni-directional mode and directional mode (details will be addressed in Section 2.3) have different transmission ranges, though the reception range is the same. If there is an interface per sector (each antenna), its omni-directional and directional modes have the same transmission range.

## 2.2. Radiation patterns for directional antennas

The radiation pattern of an antenna is the 2D or 3D spatial distribution of antenna gain as a function of the observer's position along a path or surface of constant radius. A typical antenna radiation pattern in 3D space is shown in Figure 3. The gain of an antenna is defined as

$$G(\theta, \phi) = \eta \frac{U(\theta, \phi)}{U_{\text{ave}}} \quad (1)$$

where  $\theta$  is the angle between the  $z$ -axis and the vector  $\mathbf{r}$ , and  $\phi$  is the angle between the  $x$ -axis and the projection of the vector  $\mathbf{r}$  into the  $x$ - $y$  plane. The vector  $\mathbf{r}$  represents the radiation *lobe*, which is a portion of the radiation pattern bounded by regions of relatively weak radiation intensity [31].  $U(\theta, \phi)$  is the power density in direction  $(\theta, \phi)$ ,  $U_{\text{ave}}$  is the average power density over all directions, and  $\eta$  is the efficiency of the antenna. If the antenna radiates power equally in all directions, then  $U(\theta, \phi)$  will be equal to  $U_{\text{ave}}$ , and the antenna is an omni-directional antenna (isotropic). The angle pair  $(\theta, \phi)$  is called the *direction of arrival* (DoA). A single  $\theta$  or  $\phi$ , called the *angle of arrival* (AoA), represents the direction of the received signal. The power gain  $G(\theta, \phi)$  of an antenna is the ratio of radiation intensity to average intensity over all directions. In general, a directional antenna has a main lobe (beam) of the peak gain and sidelobes/backlobes of smaller gains, which account for

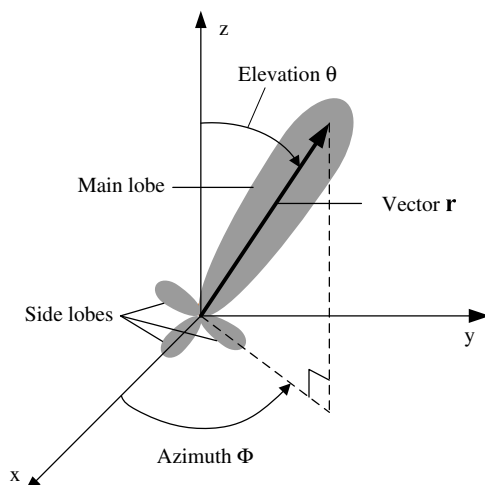

Figure 3. Radiation patterns.

nothing but interference to other nodes. As the radiation pattern of a directional antenna is too complicated to be used in analysis, there are two simplified models for radiation patterns of directional antennas:

- *Flat-top radiation pattern*: This model assumes that the antenna gain is constant within the main beam with *beamwidth*  $\theta$  and both sidelobes and backlobes are ignored (i.e., the gain outside the beamwidth is regarded as zero). As shown in Figure 4(a), for a beam with beamwidth  $\theta$  in the azimuth plane, the gain is defined as

$$G = \frac{2\pi}{\theta} \quad (2)$$

where  $\theta \geq \theta_{\min}$  and  $\theta_{\min}$  is the minimum achievable beamwidth.

- *Cone+Sphere radiation pattern*: This approximated model is first proposed in [8]. As shown in Figure 4(a), the antenna pattern for the antenna gain consists of a main lobe with the beamwidth  $\theta$  and a side lobe with a beamwidth  $2\pi - \theta$ . The main lobe is modeled as a *cone* of uniform gain, and the sidelobes are aggregated to a single *bulb* at the base of the cone.

Both the flat-top model and the cone+sphere model have been used in many current studies on outdoor directional systems (as shown in Table IV) although they are too simple to analyze the real impacts of directional antennas on DAWNs. But not all studies use the less accurate analytical models. Instead, many real directional systems (both indoor and outdoor DAWNs) either make decisions on the basis of measurements, such as Increasing Indoor Wireless Capacity Using Directional Antennas (DIRC) [32, 33], multi-directional-antenna systems (MiDAS) [34], indoor switched beams [35], multi-sector antenna systems [36], and Wi-Fi directional access points (APs) [37],

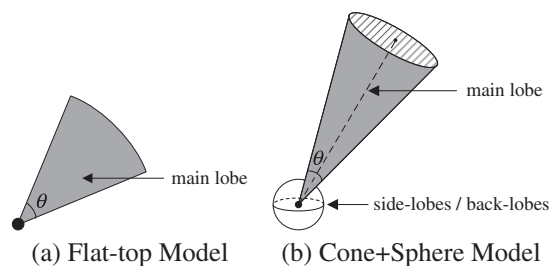

Figure 4. Two radiation patterns of directional antennas.

or use the realistic antenna radiation models including long-distance mesh networks [38–40] and utilizing directional antennas for ad hoc networking (UDAAN) [11].

### 2.3. Antenna modes of directional antennas

In general, directional antennas have two modes to transmit or receive: the omni-directional (Omni) mode and the directional (Dir) mode. The Omni mode is achieved through turning on all the sectors of switched-beam antennas, adjusting beam pattern of adaptive array antennas or using an omni-directional antenna. The Dir mode is realized by switching on one sector of switched-beam antennas or utilizing analog beamforming or digital beamforming of adaptive array antennas. An antenna in the Dir mode usually has a higher antenna gain than that in the Omni mode. As shown in Table I, there are four combinations for the transmitter (TX) mode and the receiver (RX) mode: (I) both the transmitter and the receiver are in the Omni mode; (II) the transmitter is in the Omni mode and the receiver is in the Dir mode; (III) the transmitter is in the D mode and the receiver is in the Omni mode; (IV) both the transmitter and the receiver are in the Dir mode.

Among the four cases, case I usually applies to WONs. Case II rarely happens because the receiver cannot know the location of the transmitter if it is in the Dir mode. Case III is often assumed in DAWNs as it is easy to solve the localization problem and the neighbor discovery problem (will be addressed in Section 3.1.2) when the transmitter is in the Dir mode and the receiver is in the Omni mode. Case IV is the most preferred mode in DAWNs. This is because the maximum transmission antenna gain  $G_t$  and the maximum reception antenna gain  $G_r$  can be achieved when both the transmitter and the receiver are in the Dir mode. According to Friss's free space equation [41], the communication range between the transmitter and the receiver can be maximized in this case. Besides, it requires the minimum power to reach the given communication range. In addition, when both the transmitter and the receiver are in the Dir mode, they cause the minimum interference to other nodes. However, scheduling antenna beams to face each other at the same time in case IV is still a challenge (details about the solutions will be presented in Section 3.1.2). Most current studies circumvent the problem by assuming the Omni mode at the receiver (case III).

### 2.4. Challenges

Although directional antennas have numerous advantages, there are many research challenges in the physical layer, which restrict the application of directional antennas from wireless networks.

**2.4.1. Computation complexity and physical size.** To enable beamforming and other capabilities, such as nulling to interference and mitigating multipath signals, a directional antenna must have a powerful processing unit (e.g., DSP unit) and a mighty control unit. It is a challenge to equip wireless ad hoc networks with directional antennas, where many portable devices only have a low-processing capability.

On the other hand, the bulky physical size of directional antennas brings a challenge to deploy directional antennas to wireless networks. In general, the antenna gain heavily depends on the number of antenna elements. Every two elements must be separated by at least a half wavelength. For example, a 2.4-GHz antenna requires about 8-cm separation between two elements [42]. This inevitably leads to bulky size of directional antennas, which makes it more difficult to deploy directional antennas to wireless networks.

However, with the evolution of integrated circuit and wireless communications, more and more inexpensive, powerful, and tiny processing units will be available to the portable devices in wireless

Table I. Antenna modes of directional antennas.

|    |      | RX             |               |
|----|------|----------------|---------------|
|    |      | Omni           | Dir           |
| TX | Omni | Omni–Omni (I)  | Omni–Dir (II) |
|    | Dir  | Dir–Omni (III) | Dir–Dir (IV)  |

networks. For example, a compact ultra wideband antenna with dimensions of (0.9 cm × 1 cm) is used in the breast imaging system [43].

*2.4.2. Impact of directionality.* Although the *directionality* enables directional antennas to concentrate the accepting capability or the sending capability on a direction and weakening the capability on other directions, it also leads to challenges on upper layers, especially for MAC layer.

One of the challenges brought by the directionality of directional antennas is directional carrier sensing (DCS). In a typical carrier-sensing multiple access (CSMA) MAC protocol, a transmitter must listen to the medium first before it initiates its transmission in order to avoid collisions with other on-going transmissions. More specially, the transmitter will compare the signal strength measured from the analog circuit with the given SINR threshold. If the signal strength is greater than the threshold, it indicates that the medium is busy; otherwise, it indicates that the medium is available. Different from omni-directional antennas, which can conduct carrier sensing easily, DCS is more challenging because of the directionality of directional antennas as well as different beamforming mechanisms, which heavily depend on antenna types. It is feasible for a switched beam antenna (or a sectored antenna) to conduct DCS as it can determine which sector has the highest signal strength and whether it is greater than the threshold. For an analog beamforming antenna (belonging to adaptive arrays), DCS is also feasible as it can calculate the direction of signal by conducting *weighted-sum* algorithm at analog circuit. But DCS is not feasible for a digital beamforming antenna as the weighted-sum operation is carried out at base-band [42].

Another challenge is how to determine the direction of the receiver or the transmitter. In particular, it is involved with two sub-problems: (i) localization and (ii) neighbor discovery. The first one is to determine the absolute or reference location of each node in the network. It can be solved by either GPS-based methods or GPS-free methods. The neighbor discovery is to determine where neighbors of a node are. More specifically, when the transmitter begins to transmit, it must know the direction of the receiver; when the receiver begins to receive, it must know the direction of the transmitter. It is easy to solve the neighbor discovery problem when either the transmitter or the receiver is in the Omni mode. But it is challenging for the case that both the transmitter and the receiver are in the Dir mode. Detailed discussions on these problems will be presented in Section 3.

### 3. MAC ISSUES WITH DIRECTIONAL ANTENNAS

The unique characteristics of directional antennas make the MAC design in DAWNs more challenging than that in WONs. In Section 3.1, we introduce MAC issues on DAWNs. Sections 3.2 and 3.3 present a classification of current MAC protocols and a comparison of the protocols, respectively. In Section 3.4, we discuss open research issues in the MAC design on DAWNs.

#### 3.1. MAC issues in DAWNs

##### 3.1.1. Impacts of antenna types, radiation patterns, and antenna modes

###### *Impacts of antenna types*

Most of the MAC protocols for DAWNs are based on either switched beam antennas (sectored antennas) or adaptive array (steerable beam) antennas. The MAC protocols for switched beam antennas, although not as complicated as those for adaptive array antennas, have to deal with more complex issues than omni-directional antennas. When a node is about to transmit a packet, it must select a sector (beam) first. If the destination is unknown, it may have to transmit the Request to Send (RTS) frame on all sectors. Secondly, the idle node is normally monitoring incoming signals on all sectors and enables one of them only when the direction of signal is determined. This may discount the benefit gained from the sectored antennas as their transmission range may be reduced to the directional–omni-directional (Dir–Omni) range or even the omni-directional–omni-directional (Omni–Omni) range. Supporting simultaneous transmissions is another challenge for MAC design in DAWNs. The MAC protocols that assume to use switched beam antennas include directional



MAC (DMAC) [6], Nasipuri's protocol [7], circular-DMAC [23], MAC protocol for directional Antennas (MDA) [25], Receiver-Initiated Directional MAC (RI-DMAC) [26], Dual Busy Tone Multiple Access for Directional Antennas (DBTMA/DA) [27], tone DMAC [28], Busy-Tone based Directional MAC (BT-DMAC) [29], and Synchronized Directional MAC (SYN-DMAC) [44].

Steerable single beam antennas and adaptive array antennas have more advantages than switched beam antennas, for example, the further reduced interference and the mitigated multipath fading. However, the MAC becomes more difficult because of the directional beamforming. In particular, when a receiver equipped with a steerable beam antenna has no knowledge of the transmitter, it must determine where and when to point to the transmitter. Furthermore, as the antenna beam of the transmitter is pointed to a specific direction when the transmission is in progress, it cannot know the transmissions from other nodes. It results in the new hidden terminal problem and the deafness problem (they also happen in the networks with sectored antennas), which will be described in Section 3.1.3. In most cases, a MAC protocol needs to be designed for a specific antenna system although the MAC protocols for directional antennas may share some common properties. The MAC schemes using adaptive array antennas include directional virtual carrier sensing (DVCS) [9], multi-hop MAC (MMAC) [10], Ready-to-Receive Spatial Directional Multiple Access protocol (RTR-SDMA) [45], Smart Antennas Based Wider-range Access MAC Protocol (SWAMP) [46], Smart-Aloha [47], receiver-oriented multiple access (ROMA) [48], and directional transmission and reception algorithm (DTRA) [49].

#### *Impacts of radiation patterns*

The radiation patterns of directional antennas have impacts on the network performance. As shown in Section 2.2, an antenna pattern typically includes a main lobe and several sidelobes and backlobes, which account for nothing but interference. Generally, there are several approaches dealing with sidelobes and backlobes: (i) simplifying or ignoring side/backlobes; (ii) using the nulling capability of the directional antenna to mitigate the effects of sidelobes and backlobes; and (iii) simultaneous transmission or reception to reduce the effects of sidelobes and backlobes.

As mentioned in Section 2.2, the flat-top model and the cone+sphere model are used for analyzing radiation patterns of directional antennas. The flat-top model is assumed in many protocols including DMAC [6], Nasipuri's protocol [7], circular-DMAC [23], MDA [25], RI-DMAC [26], DBTMA/DA [27], BT-DMAC [29], and SYN-DMAC [44], in which the sidelobes and backlobes are ignored. Other protocols including MMAC [10] and MAC proposed by Ramanathan [8] assume the approximated cone+sphere model. Although the simplified models facilitate the analysis on MAC protocols, they cannot depict the realistic impacts of directional antennas in DAWNs. For example, the sidelobes and backlobes can significantly affect the network throughput [9, 11].

Another technique is the nulling capability of directional antennas, which can reduce the effects of sidelobes. Several proposed protocols have exploited the nulling capability to reduce the interference and maximize the SINR. In [45], a spatial null angle vector is used to modify the radiation pattern by placing nulls in appropriate directions. Singh *et al.* [47] exploited the nulling capability of directional antennas and achieved significantly performance improvements.

Instead of mitigating sidelobes or backlobes, many researchers propose protocols to reduce the effects of sidelobes and backlobes by directing the sidelobes and backlobes to other directions or circumventing sidelobes and backlobes through synchronizing transmissions or receptions. In particular, the ROMA protocol [48] steers the sidelobes toward areas without nodes (or the nodes that cannot be reached) by using the spatial adaptability of directional antennas. Raman and Chebrolu [38] proposed a two-phase (2P) protocol for wireless networks with long-distance links. It is shown in [38] that it is possible to simultaneously activate all outgoing links (transmit) or incoming links (receive) at a node even with the presence of sidelobes and backlobes when the power at each link is properly set.

#### *Impacts of antenna modes*

As mentioned in Section 2.3, there are the Omni mode and the Dir mode for directional antennas. When a directional antenna is in the Dir mode, it concentrates its *directionality* to a certain direction

and consequently leads to the improved signal strength and the increased communication range. The increased communication range by using directional antennas can help in reducing the number of hops between the source and the destination. Besides, the increased communication range can also improve the network connectivity by bridging the disjoint network partitions [13, 50]. When a directional antenna is in the Omni mode, it can be regarded as an omni-directional antenna, which has a shorter communication range than that in the Dir mode. Therefore, depending on whether the Dir mode is used at either the transmitter, or the receiver or both, the transmission range varies from the Dir–Omni range to the Dir–Dir range. When both the transmitter and the receiver are in the Dir mode, the transmission range is maximized. The transmission range is shortened when the Omni mode is used at both the transmitter and the receiver. As the receiver does not know about any transmission attempts from the transmitter, it has to listen in the Omni mode when it is idle. Therefore, the range extension is often shortened to the Dir–Omni range. MMAC [10], UDAAN-DMAC [11], and DTRA [49]) attempt to extend the communication range to the Dir–Dir range. In particular, MMAC [10] delivers multi-hop RTS frames to the receiver over a number of hops so that a communication within the Dir–Dir range is established. DTRA [49] and UDAAN-DMAC [11] proposed a synchronized mechanism to schedule the transmitter and the receiver to face each other within Dir–Dir range.

Using directional antennas in DAWNs increases not only the communication range but also the *interference* range, which is usually proportional to the communication range. The increased interference range leads to more nodes suffering from the interference. Therefore, proper power control with directional antennas is necessary for the MAC design on DAWNs. Takai *et al.* [51] proposed a preliminary power control scheme in DAWNs, in which they used the reception range control instead of the transmission range control. Through this way, the range-extended communication will not interfere with on-going communications. It is also shown in [51] that this mechanism can dramatically improve the packet delivery ratio.

### 3.1.2. Localization and neighbor discovery

#### *Localization*

Localization is to determine the location of a node in the network. Localization of nodes in DAWNs is critical because a node must know the direction of its intended receiver before initiating a transmission. To achieve this, each node should have a reference location in the network.

One kind of the approaches to obtain the location of a node is to use a location determination hardware, for example, a GPS receiver. Many studies [6, 26, 28–30, 45] assume that GPS-based localization is used. However, in addition to the economic factors of GPS devices, the self-limitations of GPS devices have restrained the application of GPS devices from wireless networks. Firstly, expensive receivers are needed to be mounted on GPS devices as the received signal strength of GPS is usually quite low. Besides, unobstructed views are required for GPS, which usually cannot work indoors. Moreover, the inquiry of destination position produces additional traffic load [52].

There are other GPS-free methods to estimate the location of a node. These techniques typically use distance or angle measurements from some reference points and apply triangulation to locate the node [53]. The distance or angle estimates may be obtained from received signal strength (RSSI) measurements, time of arrival (ToA), time-difference-of-arrival (TDoA) measurements, and AoA measurements. But non-uniform propagation environments make RSSI methods unreliable. The major drawback of ToA and TDoA measurements is that a small measurement error can cause a large estimation error due to the high propagation speed of wireless signals. ToA and TDoA techniques often need to use a signal with a slower propagation speed, such as ultrasound, and it can give an accurate measurement but requires additional hardware to receive the ultrasound signal. AoA measurement uses directional antennas to estimate the AoA of the received signal from a beacon node. The main limitation for the AoA method is the possibility of error in estimating the directions caused by multipath reflections. The protocols that utilize AoA or DoA schemes include that of Nasipuri *et al.* [7], DVCS [9], circular-DMAC [23], DBTMA/DA [27], Smart-802.11b, and Smart-Aloha [47].

### Neighbor discovery

Neighbor discovery is another critical issue in DAWNs. After each node obtains its location in the network, it must know the location information of its neighbors before it initiates the transmission. The neighbor discovery in DAWNs is more challenging than that in WONS as it is hard to determine where to point and when to point the antenna for transmission or reception [11]. Furthermore, it is extremely difficult for blind transmit and receive beamforming (TR-BF) discovery as two nodes in the Dir mode can find each other only if they are adjusting their antenna beams toward each other at the same time.

We divide the issues on neighbor discovery into two types: the *informed discovery* and the *non-informed discovery* (blind discovery) as shown in Table II. There are several solutions to the informed discovery and the non-informed discovery. In the informed discovery, a node can obtain location information of other neighbors by AoA caching [9], location table maintenance [23], the gossip-based algorithm [55], and RTS multi-hop routing [10]. In particular, as shown in [9], each node caches the estimated AoAs from neighboring nodes when it hears any signal, regardless of whether the signal is intended for the node. The cache will be updated or invalidated if the neighboring nodes are moving away or dead. The drawbacks of this method include the low effectiveness of capturing neighbor information and refreshing caches too frequently because of the mobility of nodes. The study [23] uses the location table to store the neighbor directions through overhearing RTS or Clear to Send (CTS) frames. This method is similar to AoA caching and has the same limitation as AoA caching. Vasudevan *et al.* [55] proposed a gossip-based algorithm in which nodes can discover their one-hop neighbors through scattering the location information based on a certain probability. The simulation results show that the gossip-based algorithm is much faster than directed-discovery schemes including AoA caching and location table maintenance although this algorithm only works in static networks. The schemes such as AoA caching, location table maintenance, and gossip-based algorithm only consider neighbor discovery under the Omni–Omni mode or the Dir–Omni mode.

RTS multi-hop routing [10] is applicable to neighbor discovery under the Dir–Dir mode. MMAC [10] is used to forward position information with RTS/CTS control frames. Through this way, a Dir–Dir link can be established (see Section 3.2.1 for more details).

The non-informed discovery (blind discovery) is far more challenging than the informed discovery. In the blind discovery, a node can only choose the Dir mode to transmit and receive. Therefore, it is hard to let nodes know each other without pre-negotiation in advance. In particular, a blind discovery mechanism in terms of synchronized TR-BF is proposed in [11]. As shown in Figure 5, at a pre-reserved time, each node alternates randomly between sending heartbeats in one direction and listening to such heartbeats in the opposite direction. In each round, this method can help a number of pairs find each other, for example, pairs (A, B), (C, E), (D, F), and (G, I), as shown in Figure 5. All the nodes can obtain the locations of their neighbors within the limited rounds of location information exchange. Similar scanning algorithms [49, 54] are proposed to address the neighbor discovery. However, the existing schemes assume strict synchronization on each node, which may require a common clock source usually obtained from a GPS receiver. It is challenging to obtain strict synchronization in distributed wireless networks. Besides, synchronized TR-BF works well in static networks. However, it will take more rounds for nodes to find each other when nodes are moving. Thus, to design a blind neighbor discovery scheme without synchronization in mobile environments is still an open issue.

Table II. Comparisons of neighbor discovery approaches.

| Modes     | Informed discovery  |                               | Non-informed discovery             |
|-----------|---|-------------------------------|------------------------------------|
|           | Dir–Omni or Omni–Omni                                       | Dir–Dir                       | Dir–Dir                            |
| Solutions | AoA caching [9]<br>Location table [23]<br>Gossip-based [55] | RTS multi-hop routing<br>[10] | Synchronized TR-BF<br>[11, 49, 54] |

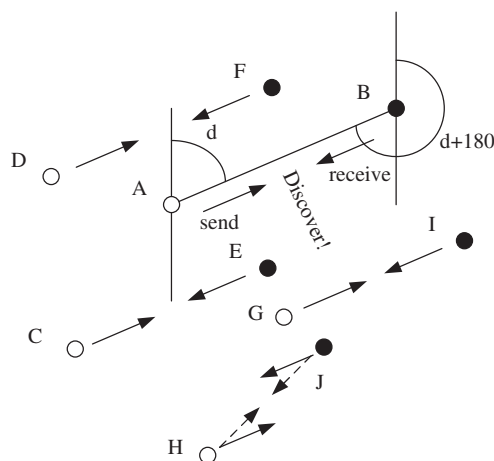

Figure 5. Blind transmit and receive beamforming discovery.

**3.1.3. Hidden terminals, exposed terminals, deafness, deaf zone, and HOLB.** The radio signal from a node significantly decays because of path loss and fading effects [41]. In the case of omnidirectional antennas, only those nodes within the transmission radius of the transmitter can detect the carrier on the channel. This location-dependent carrier-sensing results in the *hidden terminal* problem and the *exposed terminal* problem [56]. In particular, the nodes outside the transmission range of the transmitter but inside the reception range of the receiver will interfere with the receiver, which are called the hidden nodes. On the other hand, the nodes within the range of both the transmitter and the receiver are called the exposed nodes, which suffer from suppression of the transmission between the transmitter and the receiver. Because of the directionality of directional antennas and the directional transmission/reception regions (different from omnidirectional antennas), the new location-dependent carrier-sensing problems arise in DAWNs. More specifically, those problems include the new hidden terminal problem, the exposed terminal problem, the deafness problem, the deaf zone problem, and the HOLB problem, which will be depicted in details as follows.

#### *The hidden terminal problem*

A hidden terminal is a node that is not aware of another on-going transmission and whose transmission (including RTS/CTS/ACK (Acknowledgment) control frames and data frames) can cause collisions with the on-going transmission. There are two kinds of new hidden terminal problems due to the directionality of directional antennas: (i) the hidden terminal problem due to the asymmetry in antenna gains and (ii) the hidden terminal problem due to the unhearing of RTS/CTS frames.

The first kind of hidden terminal problem originates from *the asymmetry in antenna gains*. As shown in Figure 6, there are four idle nodes: A, B, C, and D in the Omni mode with antenna gain  $G_o$ . Firstly, node B sends a directional RTS (DRTS) to node C, and node C replies with a directional CTS (DCTS). Assume that node A is still in idle mode and far enough from node C, and node A may not hear the DCTS from C as the omnidirectional gain  $G_o$  is smaller than the directional gain  $G_d$ . Then, nodes B and C begin data transmission by pointing their transmission and reception beams to each other with a gain  $G_d$ . While the transmission between B and C is in progress, node A has data destined for node D. Node A points its directional beam toward node D to sense the channel and detects the channel in idle. Therefore, it sends a DRTS to node D. As node C is receiving in the Dir mode with a gain  $G_d$ , it is quite possible that the DRTS from node A interferes with the transmission from node C. Node A becomes the hidden terminal to nodes B and C. In other words, a transmitter in the Dir mode (with  $G_d$ ) and a receiver in the Omni mode (with  $G_o$ ) may be out of each other's range, but they may reach each other if they both transmit and receive directionally (with  $G_d$ ). This kind of hidden terminal problem arises because of different gains with the Omni mode and the Dir mode of directional antennas.

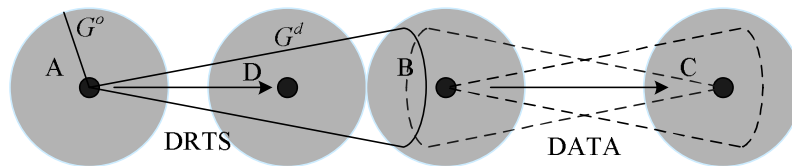

Figure 6. Hidden terminal due to the asymmetry in antenna gains.

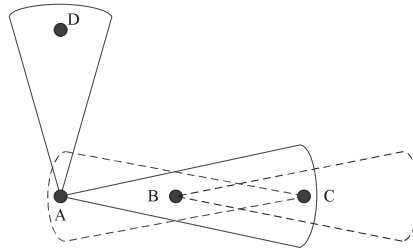

Figure 7. Hidden terminal due to the unhearing of RTS/CTS frames.

Another hidden terminal problem arises because of *unhearing of RTS/CTS frames*. In the scenario shown in Figure 7, when node A is transmitting with node D, node B sends an RTS frame to node C. At this time, node C's DCTS can reach node A. However, node A cannot hear it as A is beamformed in the direction of node D. When the communication between nodes B and C is in progress, assume that node A has finished the transmission to node D and has a packet to send to node B. Node A's directional network allocation vector (DNAV) indicates that the channel toward node B is free when node B is sending data frames to node C. Therefore, node A begins to send an RTS frame to node B, and it will lead to a collision with node B's transmission. This kind of hidden terminal problems will not happen with omni-directional antennas as node B will be aware of the transmission of node A and defer the transmission with node C.

#### *The exposed terminal problem*

The exposed terminal problem in DAWNs is a problem in which two transmissions are not allowed to proceed simultaneously, that is, one transmission is suppressed by another one, even though they will not collide with each other. Directional antennas may cause more nodes to be exposed to interference because of the increased transmission range. Take Figure 8(a) as an example. Nodes E, F, and B become the exposed terminals to nodes A and C when they are within the coverage of nodes A and C. The exposed terminal problem leads to fewer concurrent transmissions and lower spatial reuse. In particular, as shown in Figure 8, node B is blocked from communicating with node D by the transmission between nodes A and C whereas the communication between nodes B and D will not interfere with that one between nodes A and C. The phenomenon becomes noticeable when the transmission range is further increased and more nodes are covered by the antenna beams. However, using DNAV [9, 10, 46, 57] can alleviate the impact of the exposed terminal problem. Consider Figure 8(a) as an example again, where node B's DNAV records the directions of nodes A and C as the forbidden directions. But the direction toward node D is still available and B can transmit with D. More specifically, the directions (the regions with dashed lines) of node B as shown in Figure 8(b) are blocked from transmission while the white directions are still available. Similarly, nodes E and F are available to other directions except for those toward nodes C and A, respectively.

The DNAV mechanism can reduce the impacts of the exposed terminal problem and improve the spatial reuse. As a result, the network throughput is significantly improved [9, 10, 23, 29].

#### *The deafness problem*

The deafness problem, first addressed in [10], arises because of the directional beamforming. In particular, the deafness is caused when a transmitter fails to communicate to its intended receiver when the intended receiver is beamformed toward a direction away from the transmitter. As an example,

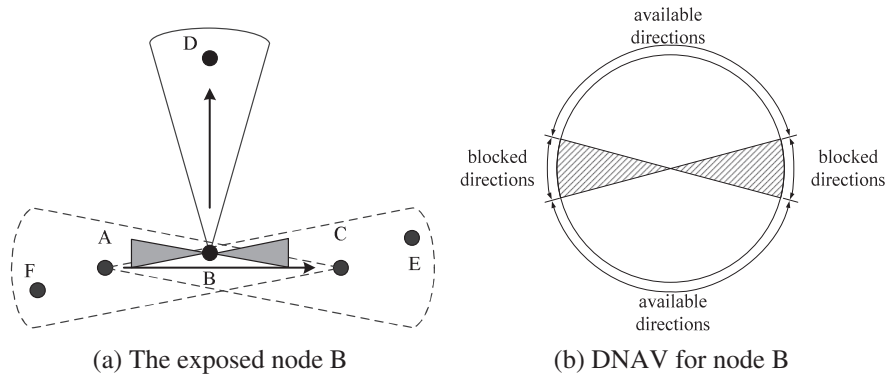

Figure 8. Directional network allocate vector combats the exposed terminal problem.

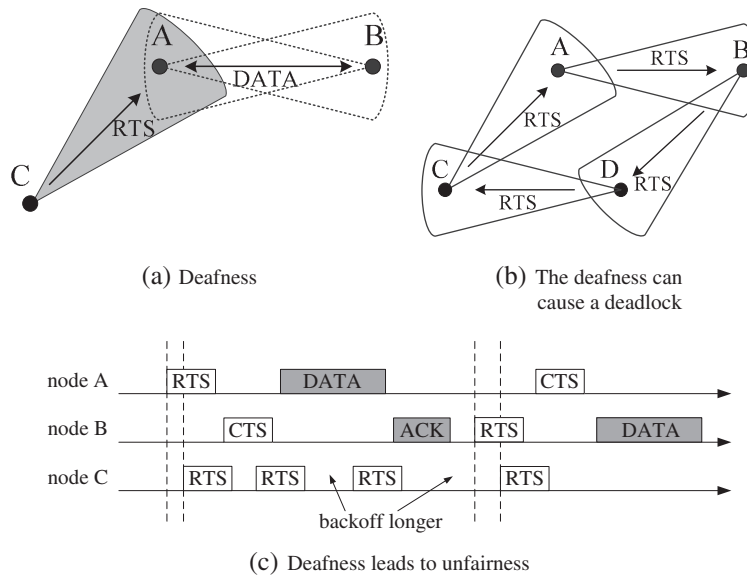

Figure 9. A scenario illustrating the deafness problem.

consider Figure 9. Node C has data frames destined for node B and it will choose to use the route through node A. When A obtains a data frame from C, it beamforms toward B and forwards the frame to node B. At this time, C is unaware of the transmission between A and B as it cannot receive the DRTS frame from node A. If it initiates the next transmission with an RTS frame to A, C will not receive the CTS reply from A as A is beamformed to B. According to the current schemes based on back-off mechanism of IEEE 802.11 distributed coordination function (DCF) [58], node C retransmits the RTS when A does not respond. This process will go on until the RTS retransmitting limit has been reached. This excessive control frame retransmission will cause the waste on the network capacity. As C would increase its back-off interval on each attempt (as shown in Figure 9(c)), the deafness problem may result in unfairness as well.

Furthermore, the deafness can also lead to a deadlock in the network. As shown in Figure 9(b), node A is beamforming toward node B and sending an RTS request. However, the antenna beam of node B is pointed to node D as node B is also sending an RTS request. Similarly, node C is also beamforming toward node A and the antenna of node D is adjusted toward node C. As each node is deaf to each other, a deadlock is caused.

*The deaf zone problem*

The deaf zone problem (first discovered in [59]) can be regarded as an extended case of the deafness problem. Essentially, the deaf zone problem arises because of the omni-directional reception of RTS

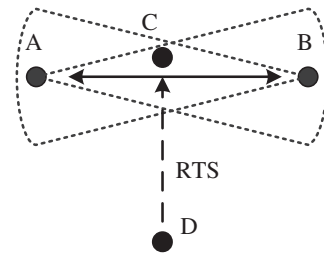

Figure 10. The deaf zone problem.

frames when a node is in idle mode. Take Figure 10 as an example: while node A is communicating with node B, node C located between A and B becomes deaf to other nodes, for example, node D. This is because node C can only receive RTS in omni-directional mode while an RTS sent from A or B has blocked C from receiving other RTS frames.

#### *The HOLB problem*

The HOLB problem arises because of the FIFO manner in wireless networks. In particular, the HOLB problem happens when the transmission direction of the foremost data packet in a node's transmission queue is blocked because of the DNAV blocking or the deafness problem. However, other data packets in the queue should not be blocked as their transmission directions may not be blocked. Take Figure 11 as an example, in which there are four nodes A, B, C, and D equipped with directional antennas. There are three packets queued at node C. Two of them are destined for node B and one is destined for node D. As the packets destined for B must be routed through A, A begins transmission with B after beamforming toward B. In this case, node A becomes deaf to node C. Thus, all the packets destined for node B from node C have to be blocked because of the deafness of node A. However, as the direction of node C to node D is not blocked, node C should not block the packet destined for node D and should transmit it instead.

*3.1.4. Solutions to the hidden terminal problem, the deafness problem, the deaf zone problem, and the HOLB problem.* Several protocols have been proposed, attempting to tackle the hidden terminal, the deafness problem [23, 25, 26, 28, 29, 44, 59, 60].

Circular-DMAC [23] attempts to address both the hidden terminal problem and the deafness problem by sending sequential DRTS frames through each antenna beam before transmitting data frames, as shown in Figure 12. In this way, the deafness problem can be solved. Consider the example as shown in Figure 9. Node C is notified by RTS frames from node A, and therefore, it will not transmit RTS toward node A. In addition, the hidden terminal problem due to the asymmetry in antenna gains may be partially solved as some nodes outside the range of DCTS may be reached by DRTS. However, this protocol may not mitigate all the hidden nodes due to the asymmetry in antenna gains as the Dir-Dir range may be much greater than the Dir-Omni range. Besides, circular-DMAC cannot solve the hidden terminal problem due to the unhearing of RTS/CTS frames. For example, as

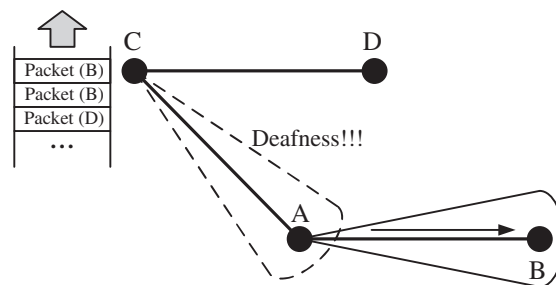

Figure 11. The head-of-line blocking problem due to the deafness problem.

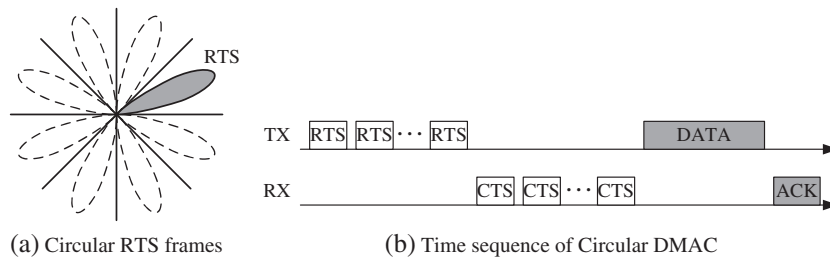

Figure 12. Circular-DMAC.

shown in Figure 7, node A cannot hear either RTS frames from node B or CTS frames from C as its antenna is pointed toward node D. Another drawback of circular-DMAC is the significant extra overhead caused by transmitting multiple RTS frames for each data frame. As shown in [23], under low traffic load, circular-DMAC performs poorer than IEEE 802.11.

Gossain *et al.* [25] proposed an improved MAC protocol (MDA) on the basis of the circular-DMAC. Although the deafness region is mitigated by sweeping multiple RTS and CTS frames in opposite directions, the deafness problem cannot be solved completely. Besides, MDA also requires sending multiple RTS and CTS frames before each data transmission, which brings additional overhead.

Other protocols including tone DMAC [28] and BT-DMAC [29] explore using tones to solve the hidden terminal and the deafness problem with low overhead on the performance. In [28], Choudhury *et al.* proposed a tone-based notification mechanism, which allows the neighbors of a node to distinguish congestion from deafness and react appropriately. For example, as shown in Figure 13, when the communication of nodes A and B is carried out, they will send busy tones omni-directionally. Now, the node C that has received the busy tone from node A deduces that the deafness is the reason for no-reply CTS from A. It will choose a shorter back-off timer to contend the channel, as shown in Figure 13(b). BT-DMAC [29] offers a better solution to both the hidden terminal problem and the deafness problem by sending busy tones through the whole communication process. It has low overhead although an additional omni-directional antenna is required to send busy tones.

RI-DMAC [26] explores a polling scheme initiated by the receiver to address the deafness problem. Although this MAC scheme performs better than both circular-DMAC [23] and tone DMAC [28], it cannot solve the deafness problem completely. Besides, RI-DMAC does nothing to the hidden terminal problem. SYN-DMAC [44] attempts to attack both the deafness problem and the hidden terminal problem. But SYN-DMAC requires strict time synchronization among all nodes, which is a challenge in wireless ad hoc networks.

DMAC with deafness avoidance (DMAC-DA) [59] is proposed to address the hidden terminal problem, the deafness problem, and the deaf zone problem. Multiple RTS or CTS frames are used before a data communication in order to avoid the possible collisions. In addition to DNAV (used

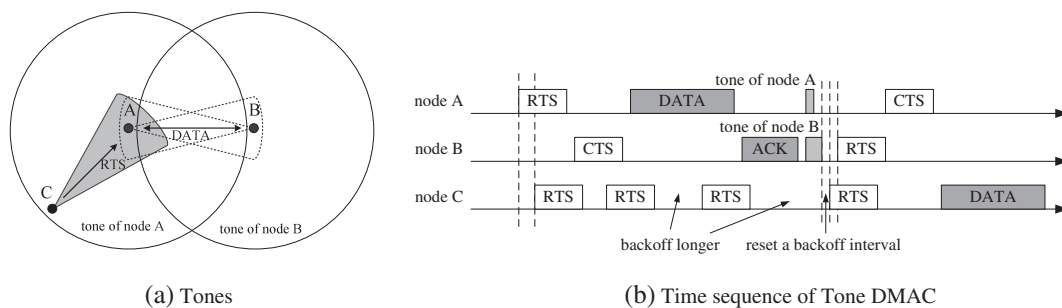

Figure 13. Tone DMAC.



to avoid collisions), a deaf neighbor table (DNT) is proposed to mitigate the deafness. However, DMAC-DA also shares some common drawbacks of circular-DMAC and MDA, that is, transmitting multiple RTS/CTS frames for each data transmission. Besides, maintaining additional DNT at each node also increases the complexity of MAC design.

The HOLB problem severely affects the network performance of DAWNs. Several studies have addressed the HOLB problem [61–64]. In particular, a new directional MAC scheme [61] based on the greedy priority scheduling is proposed. This MAC protocol establishes an interlinking queue (IQ) and a MAC queue with different packet priorities. In this protocol, the packet with the least wait time is always scheduled first. Simulation results show that this protocol can significantly improve the network performance in terms of the throughput and the end-to-end delay. However, this protocol requires making significant modifications on MAC as it requires maintaining multiple queues in MAC layer. Angular MAC (ANMAC) [62] has solved the HOLB problem by using a location-based scheduler. In particular, packets are enqueued in a queue, and if the packet at the head of the queue is destined for to a busy node, the scheduler will schedule the next packet for transmission. Similar to [61], ANMAC requires to make some modifications on MAC. Besides, ANMAC also requires transmitting multiple control frames (e.g., AN-RTS, AN-CTS) for a single data transmission, which may lead to additional overheads. Selectively directional MAC (SDMAC) [63] offers a similar solution to ANMAC by scheduling the packets in the queue. Opportunistic MAC [64] uses a similar mechanism to ANMAC by modifying the FIFO queue as a link list so that the scheduler can directly schedule the next un-blocked packet to transmit. However, most of current solutions just modify the queue scheduling mechanisms at MAC to avoid the blocked packets in the queue. Other scheduling schemes are expected in future studies.

### 3.2. Classification of MAC protocols using directional antennas

As shown in Figure 14, we categorize the current MAC protocols with directional antennas as two main categories: the random access protocols and the reservation/scheduling protocols. According to different collision avoidance approaches, we further classify random access based protocols into (i) RTS/CTS-based protocols and (ii) tone-based protocols.

#### 3.2.1. Random access MAC protocols in DAWNs

##### *RTS/CTS-based protocols*

There are a number of protocols based on DCF of IEEE 802.11, which typically uses RTS/CTS control frames to prevent interference. Except for replacing omni-DRTS/CTS frames with directional ones, directional MAC protocols have new features, including AoA caching [9], DNAV [9, 10], and beam locking [9]. In particular, DVCS is proposed to exploit the capabilities of directional antenna systems [9]. A realistic directional antenna model is adopted in this scheme. DVCS have three primary features: AOA caching, beam locking and unlocking, and DNAV. Although AOA caching

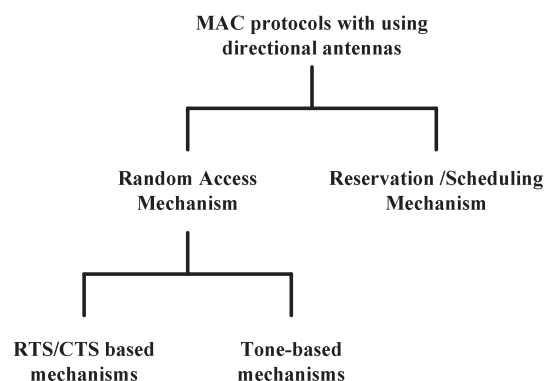

Figure 14. Classification of medium access control protocols using directional antennas.

offers an effective neighbor discovery scheme, the mobility can result in frequent cache invalidation of AoA.

The beam locking and unlocking mechanism have been used to maximize the received power and reduce signal distraction. As shown in Figure 15, node A has data frames to node B. It obtains B's direction from its AoA cache, which is stored from the last successful communication with node B. Then, it adjusts its beam toward node B and sends an RTS. Node B listens to the signals from A and then adjusts its antenna pattern to A with the maximum gain and sends a CTS back to A with the updated AoA information. Node A adjusts its antenna to the updated direction of B and *locks* the beam toward node B until the data transmission is completed. The beam locking and unlocking mechanism perform well in a static environment. But it may not be applicable to a high-speed environment as it takes time to build the locked beams of antennas (Section 3.4.2).

DNAV is a directional version of the network allocation vector in IEEE 802.11, which reserves the channel for others only in a range of directions. DNAV can increase spatial reuse, for example, mitigating the exposed terminal problem. The experimental results show three to four times capacity improvement with DVCS over omni-directional transmissions.

MMAC [10] builds on the basic DMAC protocol proposed in [6]. In MMAC, each node is equipped with two separate antennas: an omni-directional antenna and a steerable single-beam antenna. Therefore, there are the Omni mode and the Dir mode for each node. As the gain of directional antennas is greater than that of omni-directional antennas, directional antennas acquire a longer transmission range than omni-directional antennas. When both the transmitter and the receiver are in the Dir mode, the maximum communication range is achieved. However, it is very difficult to let both the transmitter and the receiver face each other when both of them are in the Dir mode. The difficulty lies in negotiating with the transmitter and the receiver and making an appointment on when and where to point the antenna toward each other.

To solve this non-informed discovery, the synchronized TR-BF scheme is proposed while it requires strict time synchronization in the whole network, which is extremely difficult in wireless ad hoc networks. MMAC solves this problem in an alternate way without synchronization. MMAC establishes the Dir-Dir link between the transmitter and the receiver by forwarding multi-hop RTS frames to the receiver through multiple Dir-Omni links. In particular, as shown in Figure 16, the Dir-Dir link consisting of nodes A and B cannot be directly reached as they do not know each other at first. Node A initiates a routing request (a DRTS frame) toward node B through the established route through nodes C and node D, where links A-C, C-D, and D-B are the Dir-Omni links. The DRTS frame is attached with the channel reservation information including the direction of node A and the time when node A wants to establish the link. When the DRTS frame is finally received by node B, node B will adjust its antenna toward node A at the time as they have negotiated before. Therefore, through the multiple RTS forwarding, a Dir-Dir link is established. In spite of the range extension to the Dir-Dir range, the multi-hop RTS scheme requires more complex upper layer support (such as link characterization and pro-active routing). Moreover, forwarding multiple RTS frames causes additional overhead on the performance.

There are many other DCF-based MAC protocols [6–8, 23, 25, 45, 46, 65–67] that are proposed to improve the performance of DAWNs. Among them, circular-DMAC [23] and MDA [25] are proposed to solve the hidden terminal problem and the deafness problem.

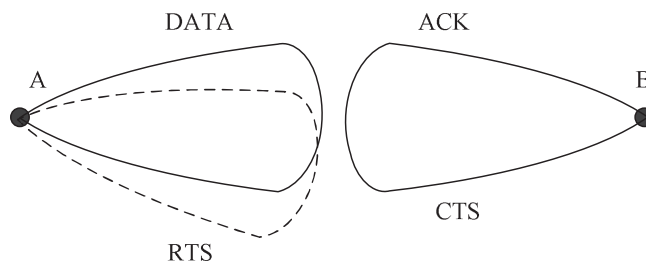

Figure 15. Beam locking in directional virtual carrier sensing.

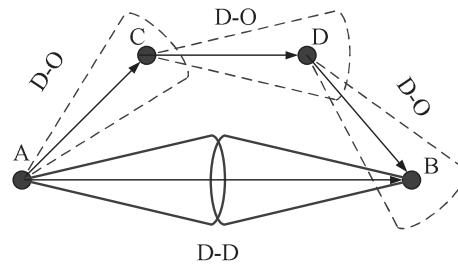

Figure 16. Multi-hop RTS routing.

#### *Tone-based MAC protocols with directional antennas*

In addition to the directional transmission of RTS/CTS control frames and data frames, transmitting tones omni-directionally or directionally can avoid collisions and solve both the hidden terminal problem and the deafness problem. Both tone DMAC [28] and BT-DMAC [29] are based on sending tones to avoid collisions. In particular, tone DMAC transmits an out-of-band tone through the same antenna after the transmission is over. This mechanism can decrease the probability of the transmission failure and increase the channel utilization. However, it cannot reduce the cost because of retransmitting RTS frames because a node will not inform its neighbors until the transmission is completed. In BT-DMAC, when the transmission is in progress, both the sender and the receiver will turn on their omni-directional busy tones to protect the on-going transmission. By combining with DNAV, the scheme almost mitigates the hidden and the deafness problems completely. However, an additional omni-directional antenna is required.

Other tone-based protocols include Smart-802.11b and Smart-Aloha [47], which exploit the nulling and DoA capabilities of the antenna and obtain a better performance than WONs. Different from tone DMAC and BT-DMAC, the tones of Smart-802.11b and Smart-Aloha are sent directionally, which are mainly used for the handshaking between the transmitter and the receiver.

Tones have many benefits, such as lower performance overhead than RTS/CTS control frames. However, unlike RTS/CTS, tones can only include limited information, which consequently lead to more potential collisions. Besides, the tones can interfere with each other as they are within the same channel. Therefore, the discriminating mechanisms or correcting schemes on tones should be further investigated in the future.

#### *Comparisons of random access schemes*

Table III compares the control message features of directional MAC protocols on the basis of random access mechanisms (RTS/CTS-based and tone-based protocols). Note that we just list the representative protocols in this table because of space limitation. It does not mean that other non-included protocols are less important. In this table, TX and RX represent the transmitter and the receiver of frames or tones, and Omni and Dir represent the omni-directional mode and the directional mode, respectively. The usage of other control frames is also indicated in the table.

Among the RTS/CTS-based protocols, the control frames are sent directionally or omni-directionally, but the RTS frames must be received only in the Omni mode as the receiver does not know the exact location of the transmitter. Therefore, the transmission range is bounded by the Dir–Omni range. After exchanging the RTS/CTS messages, the transmitter and the receiver have known each other, and consequently, the data frames and ACK frames are sent directionally.

**3.2.2. Reservation/scheduling MAC protocols in DAWNs.** The complicated collision avoidance mechanisms (RTS/CTS or tones) are required to avoid collisions for random access control protocols whereas other MAC protocols can also avoid collisions through reserving the channel or TDMA scheduling schemes.

ROMA [48] assumes to use multi-beam adaptive array, which can form multiple beams for several simultaneous receptions or transmissions and consequently increase the spatial reuse. By exchanging control frames such as RTS/CTS before each transmission, ROMA determines the

Table III. Comparisons of random access MAC protocols using directional antennas.

| Protocols                  | RTS      |      | CTS  |      | DATA |      | ACK |     | Sender tone/other frames |            | Receiver tone |          |
|----------------------------|----------|------|------|------|------|------|-----|-----|--------------------------|------------|---------------|----------|
|                            | TX       | RX   | TX   | RX   | TX   | RX   | TX  | RX  | TX                       | RX         | TX            | RX       |
| DMAC scheme 1/2 [6]        | Dir/Omni | Omni | Omni | Omni | Dir  | Omni | N/A | N/A | N/A                      | N/A        | N/A           | N/A      |
| Nasipuri <i>et al.</i> [7] | Omni     | Omni | Omni | Omni | Dir  | Dir  | Dir | Dir | N/A                      | N/A        | N/A           | N/A      |
| DVCS [9]                   | Dir/Omni | Omni | Dir  | Dir  | Dir  | Dir  | Dir | Dir | N/A                      | N/A        | N/A           | N/A      |
| MMAC [10]                  | Dir      | Omni | Dir  | Dir  | Dir  | Dir  | Dir | Dir | N/A                      | N/A        | N/A           | N/A      |
| Circular-DMAC [23]         | Dir      | Omni | Dir  | Omni | Dir  | Dir  | Dir | Dir | N/A                      | N/A        | N/A           | N/A      |
| RTR-SDMA [45]              | Dir      | Omni | Dir  | Omni | Dir  | Dir  | Dir | Dir | Omni (RTR)               | Omni (RTR) | N/A           | N/A      |
| SWAMP [46]                 | Dir      | Omni | Dir  | Omni | Dir  | Dir  | Dir | Dir | Omni (SOF)               | Omni (SOF) | N/A           | N/A      |
| MDA [25]                   | Dir      | Omni | Dir  | Omni | Dir  | Dir  | Dir | Dir | N/A                      | N/A        | N/A           | N/A      |
| DMAC-DA [59]               | Dir      | Omni | Dir  | Omni | Dir  | Dir  | Dir | Dir | N/A                      | N/A        | N/A           | N/A      |
| RI-DMAC [26]               | Dir      | Omni | Dir  | Omni | Dir  | Dir  | Dir | Dir | N/A                      | N/A        | N/A           | N/A      |
| DBTM/DA [27]               | Omni     | Omni | Dir  | Omni | Dir  | Dir  | Dir | Dir | Dir (RTR)                | Dir (RTR)  | N/A           | N/A      |
| Tone DMAC [28]             | Dir      | Omni | Dir  | Omni | Dir  | Dir  | Dir | Dir | Dir/Omni                 | Dir/Omni   | Dir/Omni      | Dir/Omni |
| Smart-802.11b [47]         | N/A      | N/A  | N/A  | N/A  | Dir  | Dir  | Dir | Dir | Omni                     | Omni       | N/A           | N/A      |
| Smart-alooha [47]          | N/A      | N/A  | N/A  | N/A  | Dir  | Dir  | Dir | Dir | Dir                      | Dir        | Dir           | Omni     |
| BT-DMAC [29]               | Dir      | Omni | Dir  | Dir  | Dir  | Dir  | Dir | Dir | Omni                     | Omni       | Omni          | Omni     |

TX, transmission; RX, reception; Dir, directional mode; Omni, omni-directional mode.

communication pair and pre-arranges a set of timetables for individual nodes. Each pair of nodes is scheduled with the predetermined time slots; thus, the transmissions are almost collision free. Another benefit of ROMA is that both transmitters and receivers are allowed to use the Dir mode, which leads to a longer transmission range and a higher spatial reuse over the Dir–Omni mode. The hidden terminal problems are also solved in this protocol.

Zhang [49] proposes a DTRA in wireless ad hoc networks. Each node is assumed to be equipped with a steerable antenna. In DTRA, time is divided into frames and each frame is split into three sub-frames: one sub-frame is used for neighbor discovery and three-way handshaking, another one is devoted to reconfirming connection and reserving data frames, and the final sub-frame is used for the actual data transmission. One of DTRA's key features is the scanning algorithm for neighbor discovery, which is quite similar to synchronized TR-BF [11]. It is shown in [49] that DTRA requires at most  $\lceil \log_2 N \rceil$  scans for any two nodes to find each other (if they can reach each other), where  $N$  is the maximum number of nodes in the network. During the neighbor discovery process, transmitters and receivers can exchange messages for possible transmission in the next step by a three-way handshaking algorithm. Reservation confirmation is quite like the three-way handshaking process in neighbor discovery except for the different message contents.

A directional MAC protocol based on the time synchronization mechanism, called SYN-DMAC, is proposed in [44] to tackle the deafness problems and the hidden terminal problem. SYN-DMAC also divides a transmission cycle into three phases: random access phase, data phase, and ACK phase. Random access phase serves as channel reservation and route discovery (including neighbor discovery). During the channel reservation, an improved shaking-hand mechanism based on RTS–CTS–CRTS is proposed while a new control frame confirmed RTS (CRTS) is used. After the random access phase, multiple collision-free data transmissions proceed in parallel. Similar to data transmission phase, parallel ACK transmissions are also contention free. In SYN-DMAC, nodes have a shorter vulnerable time to the deafness and the hidden terminals. However, the hidden terminal and the deafness problem cannot be solved completely during the random access phase.

A new MAC protocol, called 2P, is proposed for 802.11 mesh networks with long-distance links, though this scheme can potentially be used in multi-hop networks [38]. Each node in this network is equipped with a parabolic grid directional antenna (i.e., a kind of the traditional directed antennas) and multiple transmissions are allowed in each node. Sidelobes of the antenna are considered in the protocol. When sidelobes exist, the experiments verify that it is still possible to transmit along all links of a node simultaneously (SynTx) or receive along all links of a node simultaneously (SynRx), under appropriate power settings. The 2P MAC protocol operates by switching each node between the two phases, that is, SynRx and SynTx. When switching from SynRx to SynTx, the node's neighbors have to switch from SynTx to SynRx and vice versa. This protocol is implemented in firmware and involves very little modifications to the 802.11 chipset; thus, it has low cost. The carrier-sense-based backoff and ACK are turned off to enable the SynTx/SynRx. The simulation results show that 2P can perform several times better than CSMA/CA in a long-distance 802.11 mesh network.

Compared with the random access schemes, the reservation/scheduling MAC protocols are more promising in DAWNs because these protocols offer almost collision-free solutions. The challenge with the reservation/scheduling MAC protocols lies in designing the complexed synchronization schemes in distributed wireless networks.

### 3.3. Comparison of MAC protocols in DAWNs

It is difficult to compare numerous MAC protocols in DAWNs because they have different features. In this paper, we try to summarize the common features of the different MAC protocols and give a comparison in Table IV. Similar to Table III, we just list the representative schemes in this table.

As shown in Table IV, we compare the MAC protocols according to physical features (such as antenna types and radiation patterns), MAC issues (such as the hidden terminal problem and the deafness problem), mobility, and evaluation.

In particular, most protocols assume that either switched beam antennas or adaptive array antennas are used in DAWNs. Table IV also indicates that many protocols use the simplified antenna models, such as the flat-top model for analytical purpose, although these models are too ideal to

Table IV. Comparisons of MAC protocols using directional antennas.

|                            | Antenna types                | Radiation patterns | Sidelobes | Nulling capability | Location-dependent carrier sense |                             |                       | Neighbor discovery | Mobility                          | Evaluation |
|----------------------------|------------------------------|--------------------|-----------|--------------------|----------------------------------|-----------------------------|-----------------------|--------------------|-----------------------------------|------------|
|                            |                              |                    |           |                    | Hidden terminal                  | Deafness                    | Deafness              |                    |                                   |            |
| DMAC [6]                   | Switched beam                | Flat-top           | No        | No                 | n/a                              | n/a                         | Given                 | n/a                | NS-2                              |            |
| Nasipuri <i>et al.</i> [7] | Switched beam                | Flat-top           | No        | No                 | n/a                              | n/a                         | Given                 | Low                | Simulator                         |            |
| DVCS [9]                   | Steerable single beam        | Realistic          | Yes       | No                 | n/a                              | n/a                         | AoA caching           | Low                | QualNet                           |            |
| MMAC [10]                  | Steerable single beam        | Cone+sphere        | Yes       | No                 | Proposed but still unsolved      | Proposed but still unsolved | RTS multi-hop routing | n/a                | QualNet                           |            |
| Circular-DMAC [23]         | Switched beam                | Flat-top           | No        | No                 | Solved                           | Solved                      | Location table        | n/a                | Simulator                         |            |
| RTR-SDMA [45]              | Multiple beam adaptive array | Flat-top           | No        | Yes                | n/a                              | n/a                         | Given                 | n/a                | Simulator                         |            |
| SWAMP [46]                 | Adaptive array (ESPAR [68])  | Realistic          | No        | No                 | n/a                              | Solved                      | Multi-hop routing     | n/a                | Simulator based on PARSEC Testbed |            |
| MDA [25]                   | Switched beam                | Flat-top           | No        | No                 | Solved                           | Solved                      | Location table        | n/a                | NS-2                              |            |
| DMAC-DA [59]               | Switched beam                | Flat-top           | No        | No                 | Solved                           | Solved                      | Location table        | n/a                | NS-2                              |            |
| UDAAN-DMAC [11]            | Adaptive array               | Realistic          | Yes       | n/a                | n/a                              | n/a                         | Synchronized TR-BF    | Low                | OPNET & Testbed                   |            |
| RI-DMAC [26]               | Switched beam                | Flat-top           | No        | No                 | n/a                              | Solved                      | Given                 | n/a                | Simulator                         |            |
| DBTMA/DA [27]              | Switched beam                | Flat-top           | No        | No                 | Solved                           | n/a                         | Given                 | n/a                | QualNet                           |            |
| Tone DMAC [28]             | Switched beam                | Realistic          | Yes       | No                 | n/a                              | Solved                      | Given                 | n/a                | QualNet                           |            |
| Smart-802.11b [47]         | Steerable single beam        | Realistic          | Yes       | Yes                | Not combat hidden terminal       | n/a                         | Given                 | n/a                | OPNET                             |            |
| Smart-Aloha [47]           | Steerable single beam        | Realistic          | Yes       | Yes                | Not combat hidden terminal       | n/a                         | Given                 | n/a                | OPNET                             |            |
| BT-DMAC [29]               | Switched beam                | Flat-top           | No        | n/a                | Solved                           | Solved                      | Location table        | n/a                | GloMoSim                          |            |
| ROMA [48]                  | Multiple beam adaptive array | Ideal              | No        | Yes                | Solved                           | n/a                         | Location table        | Low                | Simulator                         |            |
| DTRA [49]                  | Steerable single beam        | Ideal              | No        | n/a                | n/a                              | n/a                         | Scanning algorithm    | Low                | QualNet                           |            |
| SYN-DMAC [44]              | Switched beam                | Flat-top           | No        | n/a                | Solved                           | Solved                      | Given                 | n/a                | Simulator                         |            |
| 2P [38]                    | Parabolic grid               | Realistic          | Yes       | n/a                | n/a                              | n/a                         | Given                 | n/a                | NS-2 & Testbed                    |            |

depict real impacts of directional antennas. Besides, many protocols have been proposed to address both the hidden terminal problem and the deafness problem since they were first found in [10]. However, as mentioned before, the location-dependent carrier-sensing problems have still not been well solved (the solutions are either too complicated or have significant performance overheads). Blind neighbor discovery is another challenging issue. The solutions to this problem are either the beam-scanning algorithms based on strict time synchronization [11, 49] or the multi-hop RTS routing scheme [10].

In addition to the above issues, the mobility has also been considered in several protocols including Nasipuri's protocol [7], DVCS [9], ROMA [48], DTRA [49], and UDAAN-DMAC [11]. However, most of the schemes' protocols only work in the low-speed environments. The future MAC protocols are expected to work in the high-speed environments.

Most of the MAC protocols in DAWNs are evaluated by either simulations or realistic experiments. In particular, DVCS [9], MMAC [10], DBTMA/DA [27], tone DMAC [28], and DTRA [49] adopt QualNet to evaluate their performance. Singh *et al.* [47] conduct their simulations on OPNET. BT-DMAC [29] is implemented on GloMoSim with the extension of directional antennas. DMAC [6] and MDA [25] are evaluated on NS-2. 2P [38] is evaluated on extends NS-2 (Extended Network Simulator package) and on a testbed. Nasipuri *et al.* [7], circular-DMAC [23], RI-DMAC [26], ROMA [48], and SYN-DMAC [44] are evaluated by self-developed simulators. SWAMP [46] is implemented on a realistic testbed. Discussions on the performance evaluation of DAWNs are presented in Section 5.2.

### 3.4. Open research problems of MAC design in DAWNs

Although various MAC protocols are proposed to address the research challenges on MAC design in DAWNs, there are a number of open research issues that need to be addressed in the future.

**3.4.1. Dense networks and sparse networks.** Many of the current studies (including most of current outdoor systems and some indoor systems [32, 33, 36]) have a common assumption that the nodes are densely distributed and the traffic is also in saturation (i.e., each node always has packets to send). In these dense networks, the collision probability of packets is quite high and many complicated schemes are proposed to mitigate the collisions (i.e., the hidden terminal problem and the deafness problem). Therefore, directional antennas are used to increase the spatial reuse in dense networks.

On the other hand, some studies are focused on sparse networks, for example, long-distance wireless networks in rural areas [38–40] and many commercial networks [34, 69–72]. In sparse networks, directional antennas are mainly used to increase the signal strength or extend the communication range. For example, the long-distance wireless networks [38–40] can extend the transmission range from less than 400 m to more than 20 km.

The collision probability in sparse networks is much lower than that in dense networks. In that case, the removal of the bulky DCF mechanisms might bring more benefits as the DCF mechanism contributes nothing but overheads when the collisions are very low. In particular, the preliminary results in [38] and [40] have shown that the usage of RTC/CTS frames and the unnecessary back-off mechanism brings significant overheads on the network throughput.

More studies on design MAC protocols in sparse networks are expected in the future.

**3.4.2. Mobility.** In addition to the above MAC issues, the mobility should be taken into account in the future as well. In general, the mobility with directional antennas is mainly involved with vehicular communications. In particular, vehicular communications can be categorized into two types: (i) vehicle to infrastructure (V2I) and (ii) vehicle to vehicle (V2V). Some previous studies [73, 74] have addressed the directional communication on V2I. However, to the best of our knowledge, there are few studies on the directional communication on V2V.

One of the challenges on V2V is how to maintain the directional antennas functioning under the high-speed environments. The current approaches, such as the beam locking/unlocking scheme and

the AoA caching mechanism [9], may not work well in the high-speed directional V2V communications. One of the limitations of the beam locking/unlocking mechanism is that it is hard to lock the beams when nodes are moving in high speed [9]. Besides, the beam locking/unlocking scheme may not be applicable to the complex network topologies, for example, a node is making a turn. Consider Figure 17 as an example. Suppose nodes A and B have locked their antenna beams while they are moving in a highway. When node A makes a right turn (A' in Figure 17) and node B is still moving forward (B' in Figure 17), both nodes A and B must unlock their beams and adjust their beams to the new directions. It is very difficult to achieve this in very short time. Moreover, AoA caching scheme also suffers from the frequent invalidation of caches because of the mobility of nodes. Similarly, the location table-based approach may become less effective in mobile environments as well. Furthermore, the mobility also brings challenges to blind discovery, for example, it takes more runs for the beam-scanning algorithm to help nodes find each other when nodes are moving.

**3.4.3. Multiple channels.** Most of current MAC protocols only consider using a single channel in DAWNs. However, the collisions significantly arise with the increased number of nodes because all the nodes are sharing the same channel. Using multiple channels may help to avoid collisions. For example, many tone-based protocols including [27, 29] use one data channel for data transmissions and one control channel for sending busy tones to notify other nodes to avoid collisions.

However, there are few studies on using multiple channels for data transmissions in DAWNs. Both theoretical and experimental results [3, 75] show that using multiple data channels in DAWNs has much more benefits than using a single channel. One of the reasons is that using multiple data channels can reduce collisions by separating conflict transmissions on different channels. Besides, using multiple data channels can support more simultaneous transmissions and consequently increase the network throughput.

But there are a number of research challenges when using multiple channels in DAWNs: (i) how to assign channels for each pair of nodes to ensure the collision-free transmission? (ii) how to assign the channels dynamically (e.g., when new nodes join the network)?

To solve the first problem, we may refer to the algorithms based on the conflict graph [76], which are mainly used to solve the collision-free scheduling problem in WONs. It is necessary to investigate whether these algorithms still work on DAWNs. The second problem is more challenging than the first problem because dynamical assignments of channels require tighter negotiation of nodes than static channel assignments. More studies are expected to solve the above issues.

#### 4. CHALLENGES ON DIRECTIONAL ROUTING

The routing in wireless ad hoc networks is more challenging than that in wired networks or wireless networks with infrastructure (e.g., wireless LAN) as nodes in decentralized networks have no knowledge about the network topology and therefore they have to establish the routing paths in ad hoc manner. Most of current ad hoc routing protocols are mainly focused on WONs. Some current

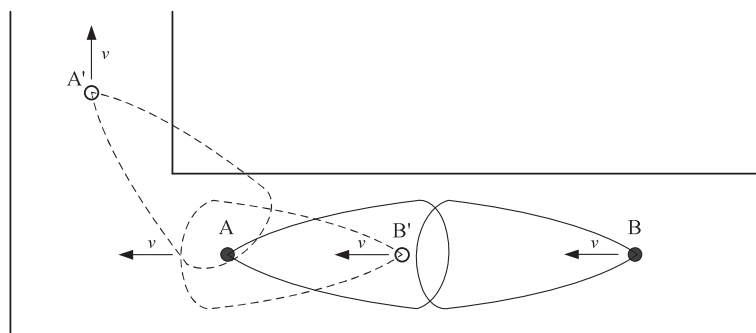

Figure 17. Beam locking in mobile environments.



studies on DAWNs directly borrow routing protocols in WONS as they treat the routing layer of DAWNs as transparent. In fact, the routing in DAWNs is much different from WONS in the following aspects: (i) sweeping delay of directional antennas, (ii) directional neighbor discovery, and (iii) impacts of location-dependent carrier-sensing problems. Such differences imply that ad hoc routing protocols in WONS may not be appropriate for DAWNs. In Section 4.1, we introduce the impacts of directional antennas on ad hoc routing. Section 4.2 presents a brief survey on the current routing protocols with directional antennas. We discuss the open research issues on ad hoc directional routing in Section 4.3.

#### 4.1. Impacts of directional antennas on ad hoc routing

As mentioned in Section 3, directional antennas have unique characteristics, which make the MAC design in DAWNs more challenging than that in WONS. These unique features of directional antennas also bring impacts on the routing design in wireless ad hoc networks.

*4.1.1. Sweeping delay of directional antennas.* Most of current ad hoc routing protocols in WONS require that nodes flood the network with the request messages by broadcasting. But to emulate omni-directional broadcasting with directional antennas requires that a node *sweeps* its antenna beams in all directions and sequentially transmits multiple requests to its neighbors, which leads to much higher delay than omni-directional antennas. Consider Figure 12 as an example, where a node is equipped with an antenna with eight beams. To broadcast route request packets in all directions, a node needs to sequentially transmit the same packet over its eight beams, as shown in Figure 12(a). Therefore, the delay caused by sweeping the beams sequentially is almost eight times higher than the delay of omni-directional antennas.<sup>‡</sup>

Moreover, the sweeping delay is increased with the increased number of beams. In general, the narrower the antenna beam, the longer the antenna can reach and the less interference it can cause. However, the narrower beam antenna also means that it has more number of beams, which leads to higher sweeping delay than the wider beam antenna. Therefore, sweeping delay seems to counteract the benefits of narrow-beam antennas more or less. The sweeping delay of directional antennas have to be considered in the design of ad hoc routing protocols in DAWNs in the future.

*4.1.2. Directional neighbor discovery.* Neighbor discovery is a necessity for ad hoc routing as the formation of the network topology requires building neighbor links. Meanwhile, neighbor discovery in DAWNs is more challenging than that in WONS because of the directionality of directional antennas. As mentioned in Section 2.3, there are three types of links in DAWNs: (i) Omni–Omni link, (ii) Dir–Omni link, and (iii) Dir–Dir link. Among them, Omni–Omni links and Dir–Omni links are easy to be established as the receiver in the Omni mode can easily obtain the direction of the transmitter through estimating AoA. However, to establish Dir–Dir links is extremely challenging as it requires both the transmitter and the receive to direct their antennas to the right directions at the right time. There are several schemes [11, 49, 54] proposed to address the Dir–Dir neighbor discovery. But most of them require the strict time synchronization, which is quite difficult in ad hoc networks. Extensive studies are expected to address the Dir–Dir neighbor discovery without synchronization.

On the other hand, Dir–Omni links and Dir–Dir links can extend the transmission range and consequently lead to fewer hops than WONS, which have Omni–Omni links only. Take Figure 18 as an example. If a routing request (RREQ) packet is sent omni-directionally from node A to B to C, the route through A–B–C has a hop count 2. If directional antennas are considered, then the RREQ packet is sent directionally from node A. It is quite possible that node A can directly reach node C as a directional antenna has a higher gain than an omni-directional antenna. Therefore, a short route A–C is established, which has a hop count 1. Using directional antennas in ad hoc routing can consequently reduce the routing delay because of the multi-hop routing. It is proved theoretically

<sup>‡</sup>The sweeping delay mainly depends on the time transmitting packets whereas the delay for switching the antenna beams is so short that it can be ignored.

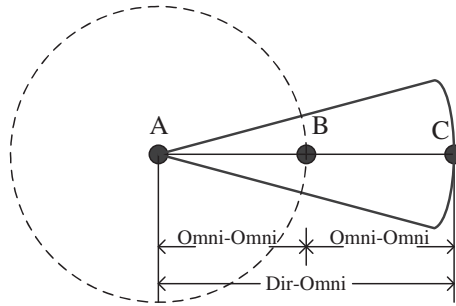

Figure 18. Using directional antennas leads to few hops.

in [14] that DAWNs have smaller routing delay than WONs. However, more efforts are expected to verify the routing improvement of DAWNs over WONs through practical experiments.

Besides, directional routing may offer a better solution to Dir-Dir discovery than synchronized TR-BF [11] scheme. In particular, consider Figure 16 (Section 3.2.1) as an example. MMAC establishes the Dir-Dir link through the multi-hop RTS forwarding mechanism. Of course, this scheme is suffering from transmitting excessive packets for a single Dir-Dir link.

*4.1.3. Impacts of the hidden terminal problem and the deafness problem.* As mentioned earlier in Section 3.1.3, the hidden terminal problem and the deafness problem of MAC layer can significantly affect the performance of DAWNs. We show as follows that the hidden terminal problem and the deafness problem can also severely affect the routing performance.

The hidden terminal problem can severely affect the routing performance. As shown in Figure 19, there is a routing path A-B-C-D. Nodes A and B can communicate with each other through a Dir-Omni link as they are within the Dir-Omni range of each other. Similarly, nodes B and C form a Dir-Omni link and nodes C and D form a Dir-Omni link. Note that in this scenario, nodes A and D can reach other nodes through a Dir-Dir link although they are outside of the Dir-Omni range of each other (as we have discussed in Section 3.1.3). Thus, node A is the hidden node to node D because of the asymmetry in antenna gains. Suppose node A has data packets to node D: DATA(1) and DATA(2) as shown in Figure 19. DATA(1) has been transmitted earlier than the packet DATA(2) as link B-C cannot be active at the same time as links A-B and C-D whereas links A-B and C-D can be active simultaneously. It is quite possible that the transmission of DATA(2) from node A will collide with the reception of DATA(1) at node D. This is because node A is the hidden node to node D when links A-B and C-D are simultaneously active. To avoid the collisions, DATA(2) should be deferred at least after DATA(1) is successfully received at node D. The hidden terminal consequently leads to the degradation on the routing performance. But it is not the case when using omni-directional antennas as nodes A and D are not hidden terminals to each other.

In addition, the deafness problem has impacts on the routing performance of DAWNs as well. Consider Figure 20 as an example, where nodes C and D choose a common routing path A-B to node B. Assume that both C and D have data packets destined at node B. Suppose that node C initiates its transmission first and A will help in forwarding C' packet. When A is on transmission to B, node D also initiates its transmission to node A. At that time, node D is unaware of the transmission

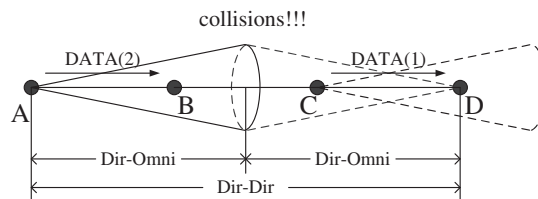

Figure 19. The hidden terminal problem affects routing.

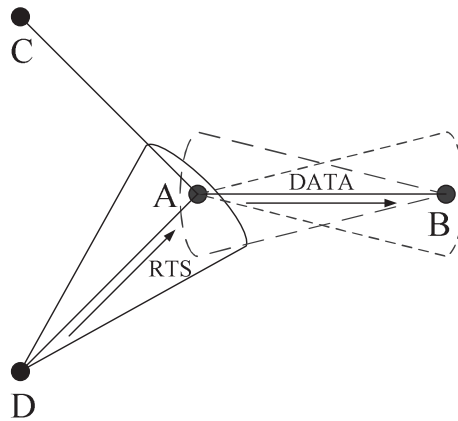

Figure 20. The deafness problem affects routing.

between A and B as it does not hear the communication of A and B. Thus, node D sends an RTS frame to node A, which consequently leads to the deafness problem. Because of the unfairness of the deafness problem (as shown in Figure 9), it is quite possible that node D could never obtain the channel if node C always has packets to send. However, this will not happen when omni-directional antennas are used (node D will be aware of the transmission of nodes A and B).

Both the hidden terminal problem and the deafness problem can severely affect the routing performance of DAWNs, which need to be considered for routing layer design on DAWNs.

#### 4.2. Directional routing protocols

Compared with extensive studies on MAC layer of DAWNs, there are a smaller number of routing protocols dedicated to directional antennas. Most of current routing protocols of DAWNs just simply adapt omni-directional routing protocols to DAWNs. However, omni-directional routing protocols may not work well in DAWNs as directional antennas have different characteristics from omni-directional antennas. For example, it is shown in [10] that the network throughput significantly degrades because of the deafness when the routes have not been properly designed.

There are several new routing protocols proposed for DAWNs. In particular, we categorized directional routing protocols into three types: pro-active, re-active, and hybrid (which combine both pro-active and re-active mechanisms), as shown in Table V.

Directional link-state routing protocol (DLSRP) [77] is a pro-active (table-driven) routing protocol, in which each node must maintain a complete routing table of the entire network. Dir-LSRP [8] is another version of DLSRP, which has the similar performance of DLSRP. Electronically steerable passive array radiator (ESPAR)-routing [50] is an improved DLSRP with load balancing. One of disadvantages of these table-driven routing protocols is the cost for maintaining the routing table at each node, which requires sending excessive node-updating messages. Besides, this type of protocols has a slower reaction on network failures.

On-demand routing using directional antennas (ORDA) [78] is one of the early studies on re-active directional routing. In particular, ORDA constraints the route request to a certain narrow angle to avoid flooding extensive messages. ARC-AODV [51] is a directional ad hoc on-demand vector (AODV) protocol with adaptive range control. DAODV [82] is another version of directional

Table V. Classification of routing protocols of DAWNs.

| Pro-active (table driven)                      | Re-active (on demand)  | Hybrid     |
|--|--|------------|
| DLSRP [77], Dir-LSRP [8]<br>ESPAR-routing [50] | ORDA [78], ARC-AODV [51],<br>DDSR [79], MDDSR [80]<br>DRP [81], DAODV [82] | DHSLs [11] |

AODV. In both ARC-AODV and DAODV, RREQs are broadcast and flooded in the entire network when the route between the source and the destination is still unknown. Then, the route is set up when route replies are relayed back from the destination to the source.

Directional dynamic source routing (DDSR) [79] is also an on-demand routing protocol. When a node has data packets to send and the routing path to the destination is unknown, it will initiate routing discovery by flooding route request packets to its neighbors. Then, each node that receives an RREQ packet will re-broadcast the RREQ until it reaches the destination. The main drawback of DDSR is that the sweeping delay due to directional broadcasting may lead to sub-optimality of routing paths. This is because sweep antenna beams lead to the neighbors of a node to obtain the same RREQ at different points of time (i.e., the shortest delay does not mean the shortest path). Besides, DDSR also suffers from flooding excessive packets to maintain the network when there are many broken links at intermediate nodes (due to the deafness).

Li *et al.* proposed an improved DDSR (multipath DDSR) [80]. This protocol shares the same routing discovery and maintenance scheme with DDSR whereas the routing table records multiple routing paths instead of a single routing path. When a link is broken, the node can choose another link to route. However, MDDSR also requires excessive messages to keep the network connected. Directional routing protocol (DRP) [81] is also a directional routing protocol based on dynamic source routing (DSR). But DRP has a better performance than DDSR as it has an enhanced routing discovery mechanism.

All the on-demand routing protocols are suffering from the high latency in routing finding and the overhead due to excessive flooding routing messages.

In addition to pro-active routing protocols and re-active routing protocols, there are some hybrid routing protocols for DAWNs. In particular, Ramanathan *et al.* [11] proposed a directional hazy sighted link state (DHLS) [83, 84] routing protocol of WONS to DAWNs. DHLS is made scale well to a large-scale network (around 1000 nodes). More specifically, DHLS establishes routing paths effectively while using the relatively small number of messages to keep the network connected. In order to achieve this, DHLS limits the propagation of updating link states through carefully setting the dissemination radius of messages. However, DHLS does not consider the sweeping delay and the impacts of the hidden terminal problem and the deafness problem.

### 4.3. Open research issues

In addition to the impacts of directional antennas on routing in DAWNs (e.g., sweeping delay, neighbor discovery, the hidden terminal problem and the deafness problem), there are other open issues on the routing layer of DAWNs.

**4.3.1. DRPs in practice.** Most of current directional routing protocols are based on existing ad hoc routing protocols, such as DSR and AODV, which are mainly designed for omni-directional antennas. As directional antennas have distinct broadcasting features from omni-directional antennas (i.e., directional antennas have higher sweeping delay than omni-directional antennas, and directional antennas bring the new hidden terminals and the deafness problem), the typical flooding mechanisms required by DSR and AODV may not perform well in DAWNs. Besides, some practical studies, such as Roofnet [85], have shown that some ad hoc routing protocols (e.g., DSR-like protocols) fail in practice because of the failure of neighboring nodes. To the best of our knowledge, there are quite few studies on practical directional routing protocols (in fact, we have only found DHLS works in real testbeds). Moreover, most of current directional routing protocols are evaluated by simulations and not by real experiments. Therefore, it is a big challenge to design routing protocols dedicated to directional antennas in practice.

**4.3.2. Mobility.** One of major concerns with directional antennas is the mobility. When nodes in DAWNs are moving, the network topology becomes unstable because of the frequent neighbor re-discovery and routing updates. The current solutions may not apply to the mobile environments as they have significant overheads to maintain the routes. For example, DDSR requires excessive messages to keep the network connected. Besides, nodes need to conduct neighbor discovery frequently

because of the mobility of the network while the current neighbor discovery schemes are inefficient. For example, AoA caching is quite slow to respond to the unstable network. Synchronized TR-BF requires many rounds of beam-scanning algorithms for neighbor discovery. MMAC requires sending excessive control packets to establish a Dir-Dir link. Therefore, more effective routing protocols adaptive to mobile environments are expected in the future.

*4.3.3. Multi-channel and multi-interface.* It is shown in studies [3, 5, 75] that using multiple channels and multiple interfaces in DAWNs can further improve the network capacity. However, routing protocols need to be re-designed for such networks. The first reason is that there are multiple routing paths available at each node equipped with multiple interfaces. It might be unnecessary to consider the sweeping delay of antenna beams as the multiple antennas at a node can be simultaneously active. The new challenges with the multi-channel and multi-interface networks lie in the channel assignment scheme with directional antennas. Secondly, the hidden terminal problem and the deafness problem might be completely solved through using multiple channels. Therefore, the broken path due to the deafness or the hidden terminal might be bridged and consequently more routing paths become available. In addition to the current criteria/metrics (e.g., the minimum end-to-end delay and the reliability of the routing path), other metrics, such as the minimum number of channels or the minimum power consumption, should also be considered in the design of routing protocols.

## 5. OTHER ISSUES

In this section, we address other issues related to DAWNs. In particular, we discuss the problems in the transport layer of DAWNs in Section 5.1. Section 5.2 presents the issues related to the performance evaluation of DAWNs. We introduce some indoor wireless networks using directional antennas in Section 5.3.

### 5.1. Transport layer

Transport control protocol (TCP) has been widely used in the transport layer of either wired networks or wireless networks. The main purpose of designing TCP is to provide a reliable, infrastructure-independent TCP with end-to-end flow control as well as congestion control mechanisms over the network layer. In particular, TCP should be un-aware whether Internet protocol is running over wired connections or wireless connections [86].

TCP performs well in wired networks with incorporating congestion control mechanisms as well as flow control scheme. However, TCP does not perform well in practical wireless ad hoc networks mainly because of the following reasons: (i) mis-interpretation of packet losses, (ii) broken routing path, (iii) the contention of wireless channel, and (iv) the unfairness. In particular, in wired networks, the packet losses are mainly due to the congestion. However, in wireless networks, many reasons can lead to the packet losses. For example, a wireless link often has a much higher BER than a wired link. Besides, the collisions due to the wireless hidden terminal problem also result in the packet losses. Moreover, the wireless routing path is less reliable than a wired one because of the mobility of wireless nodes, the fading wireless channel, and the high interference of wireless links. These facts affect both WONs and DAWNs.

There are extensive studies on TCP enhancements over WONs, including feedback-TCP [87], TCP with explicit link failure notification [88], TCP with buffering and sequence information [89], and ad hoc TCP [90]. However, to the best of our knowledge, there are quite few studies on transport layer control on DAWNs. In fact, to design a TCP in DAWNs is more challenging than that in WONs. As discussed in Section 4.1, using directional antennas in wireless ad hoc networks will bring challenges on routing, such as the sweeping delay, the new hidden terminal problem, and the deafness problem. All these impacts should also be considered in the transport layer design in the future.

Table VI. Comparisons of simulators with directional antennas.

|                      | NS-2 [93]      | GloMoSim [99]      | QualNet [95]            | OPNET Modeler [96] | EstiNet [97] |
|----------------------|----------------|--------------------|-------------------------|--------------------|--------------|
| License              | Open source    | Open source        | Commercial              | Commercial         | Commercial   |
| Directional antennas | 3rd party [94] | 3rd party [29, 91] | Built-in                | Built-in           | Built-in     |
| MAC layer            | 802.11 DCF     | 802.11 DCF         | 802.11 DCF and DVCS [9] | 802.11 DCF         | 802.11 DCF   |
| Routing              | No Dir         | No Dir             | No Dir                  | No Dir             | No Dir       |
| Transport            | TCP/UDP        | TCP/UDP            | TCP/UDP                 | TCP/UDP            | TCP/UDP      |
| Mobility             | Yes            | Yes                | Yes                     | Yes                | Yes          |

### 5.2. Performance evaluation

There are also some analytical models proposed to evaluate the performance of DAWNs. For example, Wang and Garcia-Luna-Aceves [91] proposed a performance model to evaluate the performance of directional MAC protocols, which are based on IEEE 802.11 DCF. In particular, a Markov chain model is used to represent the status of a node, in which a node is always in *Wait*, *Succeed*, or *Fail* (i.e., a heavy traffic assumption). Besides, this model also approximates the performance of the protocol in the time-slotted mode as that in the asynchronous mode so that the analysis can be simplified. Carvalho and Garcia-Luna-Aceves [92] presented a general evaluation model of DAWNs, in which a realistic antenna model and various carrier-sensing mechanisms including DVCS are taken into account.

As mentioned in Section 3.3, most of current DAWNs are evaluated by simulations, and only few of them are evaluated by real experiments on testbeds. Compared with WONs that are supported by many simulators, there are relatively fewer simulators that can support directional antennas.

Table VI presents a brief comparison of current simulators that can support directional antennas (either built-in support or third-party support). Note that we just compare the latest version of simulators, for example, NS-2 (2.34) [93],<sup>§</sup> QualNet 5.0 [95], and OPNET Modeler 15.0 [96].

Compared with commercial simulators (e.g., QualNet, OPNET Modeler, EstiNet), NS-2 and GloMoSim do not offer the built-in support for directional antennas although some third-party versions (e.g., the enhanced network simulator (TENS) [94]) can support directional antennas. Besides, although most of these simulators offer IEEE 802.11 MAC with DCF, only QualNet can support directional MAC protocol, that is, DVCS. In addition, all these simulators do not support directional routing protocols (e.g., ARC-AODV [51] and DDSR [79]). Moreover, the mobility of nodes is considered in all these simulators.

One of major challenges in the studies on DAWNs is to compare various directional protocols on a common simulation platform. This is because (i) there are quite few source codes available for directional MAC protocols; (ii) open source simulators are often complex and time consuming for learning whereas commercial ones are quite expensive; (iii) the simulation results are not always consistent (mainly because of the continuous changes of simulator source codes).

It is also challenging to evaluate the performance of DAWNs by conducting realistic experiments on testbeds (few directional testbeds available). The exemplary DAWNs include UDAAN [11], DAWN-ESPAR [46, 68], and long-distance wireless mesh networks [38–40].

The future studies on DAWNs are expected to solve the following issues: (i) a common simulator supporting typical directional MAC protocols, (ii) simulations with the routing layer and the transport layer dedicated for directional antennas, and (iii) realistic experiments on testbeds.

### 5.3. Indoor wireless networks using directional antennas

So far, our discussions are mainly focused on outdoor directional systems, which are quite different from the indoor directional systems that we are going to discuss in this section.

<sup>§</sup>We do not consider NS-3 as it does not support directional antennas even with some third-party simulators, for example, TENS [94].

5.3.1. *Differences between outdoor directional systems and indoor directional systems.* We briefly survey the current studies on indoor directional systems [32–37] and compare the design challenges of indoor systems with those of outdoor systems as follows.

- *Signal radiation environments.* In indoor environments, scattering and multipath effects often result in a non-light-of-sight (NLOS) between two nodes although a direct light-of-sight (LOS) is often achievable in outdoor environments. Besides, the LOS path in indoor environments may not be the optimal one to achieve the maximum throughput. Instead, the transmission along NLOS paths, for example, reflected paths, may avoid interference and consequently improve the network capacity [32].
- *Directional antennas.* In indoor environments, an adaptive array antenna may be too bulky to equip with each transceiver. Thus, in indoor directional systems, *gigantic* directional antennas (e.g., adaptive array antennas) are often only equipped with APs whereas *miniature* directional antennas (e.g., a passive patch antenna) or omni-directional antennas are often mounted at clients (such as laptops or smart-phones). In contrast, there are less size limitations of directional antennas on outdoor directional systems, that is, both transmitters and receivers can be equipped with any types of directional antennas.
- *MAC.* The presence of scattering and multipath effects in indoor environments often leads to higher interference than that in outdoor environments. The design on MAC protocols in indoor directional systems is more difficult than that in outdoor directional systems.
- *Routing.* Because of the space limitation of indoor environments, the multi-hop routing may not be necessary in indoor DAWNs whereas it is often addressed in outdoor DAWNs.

5.3.2. *Introduction of current indoor directional systems.* Table VII compares several typical indoor directional systems including DIRC [32], Speed [33], and MiDAS [34]. Note that there are other studies [35–37] focused on measurements of using directional antennas in indoor environments whereas there is no system design proposed in these studies. Thus, we do not list the measurements studies in Table VII. In particular, TX and RX denote the transmitter and the receiver, respectively. Dir and Omni represent the directional mode and the omni-directional mode, respectively.

DIRC [32] identifies the challenges in using directional antennas in indoor environments and proposes a system to solve these challenges. In particular, DIRC optimizes the orientations of directional antennas with low computational overhead. More specifically, a TDMA-based MAC protocol is proposed in DIRC and is proved to be more efficient than other CSMA/CA-based MAC protocols. However, a drawback of DIRC is the centralized control mechanism, which limits the scalability of DIRC. Besides, clients in DIRC are only equipped with omni-directional antennas, which have higher interference than directional ones.

MiDAS [34] studies the miniaturization of directional antennas at small mobile devices, such as smart-phones. A passive patch directional antenna [98] is used in MiDAS. This antenna without RF chain is so small that it can be mounted at small mobile devices. In particular, MiDAS studies the impacts of the rotation of mobile devices equipped with miniature antennas and the behavior of directional antennas in NLOS indoor environments. Besides, a heuristic algorithm is proposed to address the antenna selection problem.

Table VII. Comparisons of indoor directional systems and outdoor directional systems.

|         |    | Outdoor     |  | Indoor      |             |             |
|---------|----|-------------|--|-------------|-------------|-------------|
|         |    |             |  | DIRC [32]   | Speed [33]  | MiDAS [34]  |
| Antenna | TX | Dir         |  | Dir         | Dir         | Dir/Omni    |
|         | RX | Dir/Omni    |  | Omni        | Omni        | Dir/Omni    |
| MAC     |    | Distributed |  | Centralized | Distributed | Distributed |
| Routing |    | Multi-hop   |  |             | Single-hop  |             |

It is found in Speed [33] that there are significant network capacity improvements when both APs and clients are equipped with directional antennas. Besides, it is also shown in Speed [33] that a four-sector antenna with  $35^\circ$  for each one can provide 96% coverage. Because to design a distributed antenna-orientation scheme is more challenging than a centralized one (e.g., in DIRC), a greedy algorithm is proposed to incorporate with a reservation-based MAC protocol. Experimental results show that Speed performs much better than the omni-directional systems (both APs and clients are mounted with omni-directional antennas only) and just a little worse than the centralized scheme.

In most of current indoor directional systems, routing is not addressed as the traffic is traversed through only one hop. However, ad hoc multi-hop routing in indoor directional systems may be worthwhile to study in the future because the traffic will take more than one hop to route in some emerging applications.

## 6. CONCLUSION

Using directional antennas in wireless networks can bring numerous benefits, such as the reduced interference, the extended communication range, and the improved network capacity. However, the self-limitations of directional antennas restrict the wide applications of them from wireless networks. In this paper, we present a classification of research challenges on different protocol layers in DAWNs. In particular, the following research issues are expected to be addressed in the future studies.

- *Impact of directionality.* One of challenges brought by directional antennas is the localization and the neighbor discovery due to the beamforming. It is much harder to let the transmitter or the receiver adjust the antenna beam toward each other in the Dir–Dir mode than that in the Dir–Omni and Omni–Omni modes. Although synchronized beam-scanning algorithms can solve the blind discovery, it is still a challenge to apply it in a decentralized network without strict time synchronization. Although the multi-hop RTS routing algorithm offers a solution to the blind discovery without synchronization, it requires transmitting multiple control frames to establish a Dir–Dir link, which bring significant overheads.
- *The hidden terminal problem and the deafness problem* due to the beamforming. Both the hidden terminal problem and the deafness problem significantly affect the network performance in both the MAC layer and the routing layer. There are a number of MAC protocols proposed to address the problems. However, the overhead incurred by the MAC protocols is unneglectable as many of them require sending multiple control frames for one data transmission and some of them require sending tones on other channels through an extra omni-directional antenna. Light-weight and efficient MAC protocols are expected in the future.
- *Cross-layer design in DAWNs.* Research issues on one layer in DAWNs can affect the protocol design on other layers. For example, impacts of the hidden terminal problem and the deafness problem can affect not only the MAC layer but also the routing layer and the transport layer. Therefore, in order to achieve superior performance of DAWNs, it is critical to design and develop MAC protocols, routing schemes, and transport protocols together in the future.
- *Indoor systems.* The presence of multipath fading and scattering leads to the challenges to use directional antennas in wireless indoor systems. In particular, to adjust the orientations of indoor directional antennas to avoid interference is more challenging because of the significantly increased state space of the antenna directions in constructing the conflict graph. Therefore, to design an optimal algorithm with low computational overhead is crucial during the construction of indoor directional systems.

The effective solutions to the open issues above shall result in better performance of DAWNs.

## REFERENCES

1. Yi S, Pei Y, Kalyanaraman S. On the capacity improvement of ad hoc wireless networks using directional antennas. *Proceedings of ACM MobiHoc*, 2003.



2. Spyropoulos A, Raghavendra C. Capacity bounds for ad-hoc networks using directional antennas. *IEEE ICC*, 2003.
3. Dai HN, Ng KW, Wong RCW, Wu MY. On the capacity of multi-channel wireless networks using directional antennas. *Proceedings of IEEE INFOCOM*, 2008.
4. Zhang J, Liew SC. Capacity improvement of wireless ad hoc networks with directional antennae. *Mobile Computing and Communications Review* 2006; **10**:17–19.
5. Zhang J, Jia X. Capacity analysis of wireless mesh networks with omni or directional antennas. *IEEE INFOCOM (mini-conference)*, 2009.
6. Ko YB, Shankarkumar V, Vaidya NH. Medium access control protocols using directional antennas in ad hoc networks. *Proceedings of IEEE INFOCOM*, 2000.
7. Nasipuri A, Ye S, Hiromoto RE. A MAC protocol for mobile ad hoc networks using directional antennas. *Proceedings of IEEE WCNC*, 2000.
8. Ramanathan R. On the performance of ad hoc networks with beamforming antennas. *Proceedings of ACM MobiHoc*, 2001.
9. Takai M, Martin J, Bagrodia R, Ren A. Directional virtual carrier sensing for directional antennas in mobile ad hoc networks. *Proceedings of ACM MobiHoc*, 2002.
10. Choudhury RR, Yang X, Vaidya NH, Ramanathan R. Using directional antennas for medium access control in ad hoc networks. *Proceedings of ACM MobiCom*, 2002.
11. Ramanathan R, Redi J, Santivanez C, Wiggins D, Polit S. Ad hoc networking with directional antennas: a complete system solution. *IEEE Journal on Selected Areas in Communications* 2005; **23**(3):496–506.
12. Saha AK, David. Routing improvements using directional antennas in mobile ad hoc networks. *Proceedings of IEEE GLOBECOMM*, 2004.
13. Bettstetter C, Hartmann C, Moser C. How does randomized beamforming improve the connectivity of ad hoc networks. In *Proceedings of IEEE ICC*, 2005.
14. Dai HN. Throughput and delay in wireless sensor networks using directional antennas. *Proceedings of the Fifth International Conference on Intelligent Sensors, Sensor Networks and Information Processing (ISSNIP)*, 2009.
15. Lehne PH, Pettersen M. An overview of smart antenna technology for mobile communications systems. *IEEE Communications Surveys Fourth Quarter* 1999; **2**(4):2–13.
16. Schmidt KW. A survey on recent approaches to using directional antennas in mobile ad hoc networks, 2003. URL <http://medianet.kent.edu/surveys/IAD03F-ken/index.html>.
17. Robert Vilzmann CB. A survey on MAC protocols for ad hoc networks with directional antennas. *Proceedings of Eunice Open European Summer School*, 2005.
18. Dai HN, Ng KW, Wu MY. An overview of MAC protocols with directional antennas in wireless ad hoc networks. *Proceedings of International Conference on Wireless and Mobile Communications (ICWMC)*, 2006.
19. Kiran P. A survey on mobility support by MAC protocols using directional antennas for wireless ad hoc networks. *International Symposium on Ad Hoc and Ubiquitous Computing (ISAUHC)*, 2006.
20. Palomar DP, Cioffi JM, Lagunas MA. Joint Tx–Rx beamforming design for multicarrier MIMO channels: a unified framework for convex optimization. *IEEE Transactions on Signal Processing* 2003; **51**:2381–2401.
21. Yoo T, Member S, Goldsmith A. On the optimality of multiantenna broadcast scheduling using zero-forcing beamforming. *IEEE Journal on Selected Areas in Communications* 2006; **24**:528–541.
22. Aryafar E, Anand N, Salonidis T, Knightly EW. Design and experimental evaluation of multi-user beamforming in wireless LANs. In *ACM MobiCom*, 2010.
23. Korakis T, Jakllari G, Tassioulas L. A MAC protocol for full exploitation of directional antennas in ad-hoc wireless networks. *Proceedings of ACM MobiHoc*, 2003.
24. Gossain H, Cordeiro C, Agrawal DP. MDA: an efficient directional MAC scheme for wireless ad hoc networks. *Proceedings of IEEE GLOBECOM*, 2005.
25. Gossain H, Cordeiro C, Agrawal DP. Minimizing the effect of deafness and hidden terminal problem in wireless ad hoc networks using directional antennas. *Wireless Communications and Mobile Computing* 2006; **6**:917–931.
26. Takata M, Bandai M, Watanabe T. A receiver-initiated directional MAC protocol for handling deafness in ad hoc networks. *Proceedings of IEEE ICC*, 2006.
27. Huang Z, Shen CC, Srisathapornphat C, Jaikao C. A busy-tone based directional MAC protocol for ad hoc networks. *Proceedings of Military Communication Conference (MILCOM)*, 2002.
28. Choudhury RR, Vaidya NH. Deafness: a MAC problem in ad hoc networks when using directional antennas. *Proceedings of IEEE ICNP*, 2004.
29. Dai HN, Ng KW, Wu MY. A busy-tone based MAC scheme for wireless ad hoc networks using directional antennas. *Proceedings of IEEE GLOBECOM*, 2007.
30. Wang J, Fang Y, Wu D. SYN-DMAC: a directional MAC protocol for ad hoc networks with synchronization. *Proceedings of IEEE Military Communication Conference (MILCOM)*, 2005.
31. Balanis CA. *Antenna Theory: Analysis and Design*, second edn. John Wiley & Sons: New York, 1997.
32. Liu X, Sheth A, Kaminsky M, Papagiannaki K, Seshan S, Steenkiste P. DIRC: increasing indoor wireless capacity using directional antennas. *Proceedings of ACM SIGCOMM*, 2009.
33. Liu X, Sheth A, Kaminsky M, Papagiannaki K, Seshan S, Steenkiste P. Pushing the envelope of indoor wireless spatial reuse using directional access points and clients. *Proceedings of ACM MobiCom*, 2010.
34. Sani AA, Zhong L, Sabharwal A. Directional antenna diversity for mobile devices: characterizations and solutions. *ACM MobiCom*, 2010.

35. Blanco M, Kokku R, Ramach K, Rangarajan S, Sundaresan K. On the effectiveness of switched beam antennas in indoor environments. *Proceedings of International Conference on Passive and Active Network Measurement (PAM)*, 2008.
36. Lundgren H, Subramanian AP, Salonidis T, Carrera M, LeGuyadec P. Multi-sector antenna performance in dense wireless networks. *Proceedings of ACM MobiHoc*, 2009.
37. Lakshmanan S, Sundaresan K, Rangarajan S, Sivakumar R. The myth of spatial reuse with directional antennas in indoor wireless networks. *Proceedings of International Conference on Passive and Active Network Measurement (PAM)*, 2010.
38. Raman B, Chebrolu K. Design and evaluation of a new MAC protocol for long-distance 802.11 mesh networks. *Proceedings of ACM MobiCom*, 2005.
39. Patra R, Nedeveschi S, Surana S, Sheth A, Subramanian L, Brewer E. WiLDNet: design and implementation of high performance WiFi based long distance networks. *Proceedings of USENIX NSDI*, 2007.
40. Nedeveschi S, Patra RK, Surana S, Ratnasamy S, Subramanian L, Brewer EA. An adaptive, high performance MAC for long-distance multihop wireless networks. *Proceedings of ACM MobiCom*, 2008.
41. Rappaport TS. *Wireless Communications: Principles and Practice*, second edn. Prentice Hall PTR: Upper Saddle River, N.J., 2002.
42. Li G, Yang LL, Conner WS, Sadeghi B. Opportunities and challenges in mesh networks using directional antennas. *the First IEEE Workshop on Wireless Mesh Networks (WiMesh)*, 2005.
43. Abbosh A, Bialkowski M. Compact directional antenna for ultra wideband microwave imaging systems. *Microwave and Optical Technology Letters (Wiley)* December 2009; **51**(12):2898–2901.
44. Wang J, Zhai H, Li P, Fang Y, Wu D. Directional medium access control for ad hoc networks. *ACM Wireless Networks (WINET)* 2008; **15**:1059–1073.
45. Lal D, Toshniwal R, Radhakrishnan R, Agrawal DP, Caffery J. A novel MAC layer protocol for space division multiple access in wireless ad hoc networks. *Proceedings of IEEE ICCCN*, 2002.
46. Takata M, Nagashima K, Watanabe T. A dual access mode MAC protocol for ad hoc networks using smart antennas. *Proceedings of IEEE ICC*, 2004.
47. Singh H, Singh S. Smart-802.11b MAC protocol for use with smart antennas. *Proceedings of IEEE ICC*, 2004.
48. Bao L, Garcia-Luna-Aceves JJ. Transmission scheduling in ad hoc networks with directional antennas. In *Proceedings of ACM MobiCom*, 2002.
49. Zhang Z. DTRA: directional transmission and reception algorithms in WLANs with directional antennas for QoS support. *IEEE Network* 2005; **May/June**:27–32.
50. Roy S, Saha D, Bandyopadhyay S, Ueda T, Tanaka S. A networkaware MAC and routing protocol for effective load balancing in ad hoc wireless networks with directional antenna. *Proceedings of ACM MobiHoc*, 2003.
51. Takai M, Zhou J, Bagrodia R. Adaptive range control using directional antennas in mobile ad hoc networks. *Proceedings of ACM International Workshop on Modeling Analysis and Simulation of Wireless and Mobile Systems (MSWIM)*, 2003.
52. Akyildiz IF, Wang X, Wang W. Wireless mesh networks: a survey. *Elsevier Computer Networks Journal* 2005; **47**:445–487.
53. Youssef A, Youssef M. A taxonomy of localization schemes for wireless sensor networks. *The 2007 international conference on wireless networks (ICWN)*, Las Vegas, 2007.
54. Steenstrup ME. Neighbor discovery among mobile nodes equipped with smart antennas. *Proceedings of Scandinavian Workshop on Wireless Ad-hoc Networks (ADHOC)*, 2003.
55. Vasudevan S, Kurose J, Towsley D. On neighbor discovery in wireless networks with directional antennas. *Proceedings of IEEE INFOCOM*, 2005.
56. Gummalla ACV, Limb JO. Wireless medium access control protocols. *IEEE Communications Surveys and Tutorials* 2000; **3**(2):2–15.
57. Watanabe M, Mitsuhashi H, Bandai M, Obana S, Watanabe T. Empirical discussion on directional MAC protocols for ad hoc networks using practice smart antennas. *Proceedings of IEEE ICC*, 2007.
58. IEEE 802.11: Wireless LAN Medium Access Control (MAC) and Physical Layer (PHY) Specifications. IEEE 802.11 Standard, IEEE, 2007.
59. Li Y, Safwat A. On Wireless Ad Hoc Networks with Directional Antennas: Efficient Collision and Deafness Avoidance Mechanisms. *EURASIP Journal on Wireless Communications and Networking* 2008; **2008**:14. DOI: 10.1155/2008/867465.
60. Sekido M, Takata M, Bandai M, Watanabe T. A directional hidden terminal problem in ad hoc network MAC protocols with smart antennas and its solutions. *Proceedings of IEEE Globecom*, 2005.
61. Kolar V, Tilak S, Abu-ghazaleh NB. Avoiding head of line blocking in directional antenna. *Proceedings of IEEE LCN*, 2004.
62. Ulukan E, Gürbüz Ö. Angular MAC: a framework for directional antennas in wireless mesh networks. *Wireless Networks* 2008; **14**:259–275.
63. Li P, Zhai H, Fang Y. SDMAC: selectively directional MAC protocol for wireless mobile ad hoc networks. *Wireless Networks* 2009; **15**:805–820.
64. Nadeem T. Analysis and enhancements for IEEE 802.11 networks using directional antenna with opportunistic mechanisms. *IEEE Transactions on Vehicular Technology* 2010; **59**:3012–3024.

65. Sanchez M, Giles T, Zander J. CSMA/CA with beam forming antennas in multihop packet radio. *Proceedings of Swedish Workshop on Wireless Ad Hoc Networks*, 2001.
66. Fahmy NS, Todd TD, Kezys V. Ad hoc networks with smart antennas using IEEE 802.11-based protocols. *Proceedings of IEEE ICC*, 2002.
67. ElBatt T, Ryu B. The channel reservation schemes for ad hoc networks utilizing directional antennas. *Proceedings of the 5th International Symposium on Wireless Personal Multimedia Communications (WPMC)*, 2002.
68. Sun C, Hirata A, Ohira T, Karmakar NC. Experimental study of a fast beamforming algorithm for ESPAR antennas. *Proceedings of European Conference on Wireless Technologies*, 2003.
69. Phocus Array. <http://www.fidelity-comtech.com/products/phocus-array/>.
70. Ruckus Beamflex. <http://www.ruckuswireless.com/technology/beamflex>.
71. SiBeam. <http://www.sibeam.com/>.
72. Xirrus Arrays. <http://www.xirrus.com/products/arrays-80211abgn.php>.
73. Navda V, Subramanian AP, Dhanasekaran K, Timm-Giel A, Das S. MobiSteer: using steerable beam directional antenna for vehicular network access. *Proceedings of MobiSys*, 2007.
74. Subramanian AP, Navda V, Deshpande P, Das SR. A measurement study of inter-vehicular communication using steerable beam directional antenna. *Proceedings of VANET*, ACM, 2008.
75. Das SM, Pucha H, Koutsonikolas D, Hu YC, Peroulis D. DMesh: incorporating practical directional antennas in multi-channel wireless mesh networks. *IEEE Journal on Selected Areas in Communications* 2006; **24**:2028–2039.
76. Jain K, Padhye J, Padmanabhan VN, Qiu L. Impact of interference on multi-hop wireless network performance. *Proceedings of ACM MobiCom*, 2003.
77. Bandyopadhyay S, Hausike K, Horisawa S, Tawara S. An adaptive MAC and directional routing protocol for ad hoc wireless networks using ESPAR antenna. In *Proceedings of ACM MobiHoc*, 2001.
78. Nasipuri A, Mandava J, Manchala H, Hiromoto RE. On-demand routing using directional antennas in mobile ad hoc networks. *Proceedings of IEEE ICCCN*, 2000.
79. Choudhury RR, Vaidya NH. Performance of ad hoc routing using directional antennas. *Ad Hoc Networks* 2005; **3**:157–173.
80. Li Y, Man H. Analysis of multipath routing for ad hoc networks using directional antennas. *Proceedings of IEEE VTC 2004 fall*, 2004.
81. Gossain H, Joshi T, Cordeiro CDM, Agrawal DP. Drp: an efficient directional routing protocol for mobile ad hoc networks. *IEEE Transactions on Parallel and Distributed Systems* 2006; **17**:1438–1541.
82. Hu B, Gharavi H. Directional routing protocols for ad-hoc networks. *IET Communications* 2008; **2**(5):650–657.
83. Santivanez C, Ramanathan S, Stavrakakis I. Making link state routing scale for ad hoc networks. *Proceedings of ACM MobiHoc*, 2001.
84. Santivanez C, Ramanathan R. Hazy sighted link state (HSLs) routing: a scalable link state algorithm. *Technical Report*, BBN Technologies, 2001.
85. Bicket J, Aguayo D, Biswas S, Morris R. Architecture and evaluation of an unplanned 802.11b mesh network. In *Proceedings of ACM MobiCom*, 2005.
86. Hanbali AA, Altman E. A survey of TCP over ad hoc networks. *IEEE Communications Surveys & Tutorials* 2005; **7**:22–36.
87. Chandran K, Raghunathan S, Venkatesan S, Prakash R. A feedback based scheme for improving TCP performance in ad-hoc wireless networks. *Proceedings of IEEE ICDCS*, 1998; 472–479.
88. Holland G, Vaidya N. Analysis of TCP performance over mobile ad hoc networks. *Proceedings of ACM MobiCom*, 1999.
89. Kim D, Toh CK, Choi Y. TCP-BuS: improving TCP performance in wireless ad hoc networks. *Proceedings of IEEE International Conference on Communications (ICC)*, 2000.
90. Liu J, Singh S. ATCP: TCP for mobile ad hoc networks. *IEEE Journal on Selected Areas in Communications* 2001; **19**:1300–1315.
91. Wang Y, Garcia-Luna-Aceves JJ. Directional collision avoidance in ad hoc networks. *Performance Evaluation Journal* 2004; **58**:215–241.
92. Carvalho MM, Garcia-Luna-Aceves JJ. Modeling wireless ad hoc networks with directional antennas. *Proceedings of IEEE INFOCOM*, 2006.
93. The network simulator. <http://www.isi.edu/nsnam/ns/>.
94. The enhanced network simulator. <http://www.cse.iitk.ac.in/users/braman/tens/>.
95. QualNet Simulator. <http://www.scalable-networks.com/>.
96. OPNET Modeler. <http://www.opnet.com/>.
97. EstiNet. <http://www.estinet.com/>.
98. Telex, 5dBi patch antenna. <http://www.telex.com/>.
99. global mobile system simulator, 2002. <http://pcl.cs.ucla.edu/projects/glomosim/>.

## AUTHORS' BIOGRAPHIES

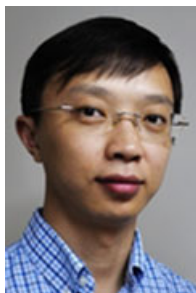

**Hong-Ning Dai** is now with the Faculty of Information Technology at Macau University of Science and Technology as an Assistant Professor. He obtained his PhD degree in Computer Science and Engineering from the Chinese University of Hong Kong in 2008. He also received his BE and ME degrees in Computer Science and Engineering from the South China University of Technology. His current research interests include wireless networks, wireless sensor networks, mobile computing, and distributed systems. He is a member of ACM, IEEE, and IEEE Communications Society.



**Kam-Wing Ng** is currently a Professor in the Department of Computer Science & Engineering at the Chinese University of Hong Kong in Hong Kong. His research interests are in distributed systems.



**Minglu Li** received his degree from the School of Electronic Technology, University of Information Engineering, Zhengzhou, China, in 1985 and his PhD degree in Computer Software from Shanghai Jiao Tong University (SJTU), Shanghai, China, in 1996.

He is a Full Professor and the Vice Chair of the Department of Computer Science and Engineering and the Director of the Grid Computing Center, SJTU. He has presided over 20 projects supported by the National Natural Science Foundation, the National Key Technology R&D Program, the 863 Program, the 973 Program, and the Science and Technology Commission of Shanghai Municipality (STCSM). He has authored or coauthored more than 100 papers published in academic journals and international conference proceedings. His current research interests include grid computing, services computing, and sensor networks.

Dr Li is a member of the Expert Committee of the ChinaGrid Program of the Ministry of Education, the Executive Committee of the ChinaGrid Forum, and the Executive Committee of the Technical Committee on Services Computing of the IEEE Computer Society. He is a Principal Scientist of the ShanghaiGrid, which is a grand project of the STCSM.



**Min-You Wu** is an IBM Chair Professor in the Department of Computer Science and Engineering at Shanghai Jiao Tong University. He serves as the Chief Scientist at Grid Center of Shanghai Jiao Tong University. He is also a Research Professor of the University of New Mexico, USA. His research interests include grid computing, wireless networks, sensor networks, overlay networks, multimedia networking, parallel and distributed systems, and compilers for parallel computers. He has published over 150 journal and conference papers in the abovementioned areas. His research has been supported by National Science Foundation, DoD, DoE, DARPA, China 863 program, China 973 program, and Natural Science Foundation of China. He is a senior member of IEEE.